

# DADF-C1

# SERVICE MANUAL

REVISION 0

**Canon**

JAN. 1999

**FY8-13FM-000**

## **IMPORTANT**

THIS DOCUMENTATION IS PUBLISHED BY CANON INC., JAPAN, TO SERVE AS A SOURCE OF REFERENCE FOR WORK IN THE FIELD.

SPECIFICATIONS AND OTHER INFORMATION CONTAINED HEREIN MAY VARY SLIGHTLY FROM ACTUAL MACHINE VALUES OR THOSE FOUND IN ADVERTISING AND OTHER PRINTED MATTER.

ANY QUESTIONS REGARDING INFORMATION CONTAINED HEREIN SHOULD BE DIRECTED TO THE COPIER SERVICE DEPARTMENT OF THE SALES COMPANY.

THIS DOCUMENTATION IS INTENDED FOR ALL SALES AREAS, AND MAY CONTAIN INFORMATION NOT APPLICABLE TO CERTAIN AREAS.

***COPYRIGHT © 1999 CANON INC.***

***Printed in Japan***

***Imprimé au Japon***

Use of this manual should be strictly supervised to avoid disclosure of confidential information.
---

Prepared by

OFFICE IMAGING PRODUCTS TECHNICAL SUPPORT DEPARTMENT 1  
OFFICE IMAGING PRODUCTS TECHNICAL SUPPORT DIVISION

**CANON INC.**

5-1, Hakusan, 7-chome, Toride-City, Ibaraki-Pref., 302-8501, Japan

# INTRODUCTION

This Service Manual provides information needed to service the DADF in the field. This Service Manual consists of the following chapters:

- Chapter 1 “General Description” introduces the DADF’s features and specifications, and shows how to operate it.
  - Chapter 2 “Basic Operation” introduces the ADADF’s mechanical and electrical systems; it also explains the principles used in these systems and the timing at which they are operated with reference to the ADADF’s electrical circuitry.
  - Chapter 3 “Mechanical System” explains the ADADF’s mechanical construction and how its parts may be disassembled/assembled and adjusted.
  - Chapter 4 “Maintenance and Servicing” provides tables of periodically replaced parts and consumables/durables and scheduled servicing charts.
  - Chapter 5 “Troubleshooting” provides tables of maintenance/inspection, standards/adjustments, and problem identification (image fault/malfunction).
- Appendix contains a general timing chart and general circuit diagrams.

The descriptions in this Service Manual are subject to change without notice for product improvement or other purposes, and major changes will be communicated in the form of Service Information bulletins.

All service persons are expected to have a good understanding of the contents of this Service Manual and all relevant Service Information bulletins, and be able to identify and isolate faults in the machine.



# CONTENTS

---

## CHAPTER 1 GENERAL DESCRIPTION

---

I.	FEATURES .....	1-1	IV.	OPERATION .....	1-5
II.	SPECIFICATIONS .....	1-2	A.	Original Set Indicator .....	1-5
	A. DADF-C1 .....	1-2	B.	Warnings and Actions .....	1-5
III.	NAMES OF PARTS .....	1-4	C.	Routine Maintenance by the User .....	1-6
	A. External View .....	1-4			
	B. Cross Section .....	1-4			

---

## CHAPTER 2 BASIC OPERATION

---

I.	BASIC CONSTRUCTION .....	2-1	E.	Reversal .....	2-20
	A. Outline of the Electrical Circuitry .....	2-1	F.	Reduced Page Composition .....	2-22
	B. Communication with the Copier .....	2-2	G.	Delivery .....	2-24
	C. Inputs to the DADF Controller PCB .....	2-3	H.	Controlling the Pick-Up Motor .....	2-27
	D. Outputs to the DADF Controller PCB .....	2-5	I.	Controlling the Belt Motor .....	2-29
II.	BASIC OPERATION .....	2-6	J.	Detecting Original Jams .....	2-31
	A. Outline .....	2-6	K.	Improper Placement of Originals .....	2-34
	B. Operation .....	2-7	III.	POWER SUPPLY .....	2-37
	C. Detecting Originals .....	2-12	A.	Outline .....	2-37
	D. Picking Up Originals .....	2-16			

---

## CHAPTER 3 MECHANICAL SYSTEM

---

I.	BASIC CONSTRUCTION .....	3-1	F.	Delivery Roller Unit (bottom pick-up mode) .....	3-20
	A. External Covers .....	3-1	G.	Delivery Roller Unit (top pick-up mode) .....	3-21
	B. Switches .....	3-3	H.	Reversing Guide .....	3-22
	C. Adjusting the DADF Height .....	3-5	I.	Stopper Plate Solenoid .....	3-24
II.	DRIVE SYSTEM .....	3-6	J.	Positioning the Paper Retaining Plate Solenoid (SL2) .....	3-25
	A. Removing the Pick-Up Motor Unit .....	3-6	K.	Positioning the Paper Deflecting Solenoid (SL3) .....	3-26
	B. Removing the Feeder Motor Unit .....	3-6	L.	Stamp Solenoid .....	3-26
	C. Belt Motor .....	3-7	M.	Feeding Belt .....	3-28
	D. Removing the Clutch Unit .....	3-9	IV.	CLEANING .....	3-31
	E. Delivery Motor .....	3-10		A. Belt Assembly .....	3-31
III.	FEEDING SYSTEM .....	3-11		B. Sensors .....	3-31
	A. Pick-Up Roller .....	3-11		C. Separation Guide .....	3-34
	B. Removing the Separation Belt Unit .....	3-12	V.	FEEDING .....	3-35
	C. Feeding Roller Unit .....	3-12		A. Pick-Up Drive Assembly .....	3-35
	D. Registration Roller .....	3-14		B. Right Delivery Drive Assembly .....	3-35
	E. Delivery/Resersing Roller .....	3-16			

---

## CHAPTER 4 MAINTENANCE AND SERVICING

---

I.	PERIODICALLY REPLACED PARTS .....	4-1	III.	SCHEDULED SERVICING CHART .....	4-2
II.	CONSUMABLES AND DURABLES .....	4-1			

---

## CHAPTER 5 TROUBLESHOOTING

---

I.	STANDARDS AND ADJUSTMENTS.....	5-1	B. PCB .....	5-22
	A. Mechanical System .....	5-1	IV. VARIABLE RESISTORS, LIGHT-EMITTING DIODES, AND CHECK PINS BY PCB.....	5-23
	B. Electrical System .....	5-11	A. DADF Controller PCB .....	5-23
II.	TROUBLESHOOTING .....	5-15	B. Indicator PCB .....	5-25
	A. Troubleshooting Malfunctions .....	5-15	C. DIP Switch Functions .....	5-26
III.	ARRANGEMENT OF THE ELECTRICAL PARTS .....	5-20	V. SELF DIAGNOSIS .....	5-28
	A. Motors, Solenoids, and Sensors .....	5-20	A. DADF Self Diagnosis .....	5-28

---

## APPENDIX

---

A.	GENERAL TIMING CHART .....	A-1	D. DADF CONTROLLER CIRCUIT DIAGRAM.....	A-4
B.	NAMES AND ABBREVIATIONS OF SIGNALS .....	A-2	E. DISPLAY BOARD .....	A-11
C.	DADF-C1 GENERAL CIRCUIT DIAGRAM.....	A-3	F. SPECIAL TOOLS .....	A-12
			G. SOLVENTS AND OILS.....	A-13





---

# CHAPTER 1

---

## GENERAL DESCRIPTION

---

I. FEATURES .....	1-1	IV. OPERATION .....	1-5
II. SPECIFICATIONS .....	1-2	A. Original Set Indicator .....	1-5
A. DADF-C1 .....	1-2	B. Warnings and Actions .....	1-5
III. NAMES OF PARTS .....	1-4	C. Routine Maintenance	
A. External View .....	1-4	by the User .....	1-6
B. Cross Section .....	1-4		



# I. FEATURES

## 1. Original Size Identification

The machine can identify the size of an original in terms of its length (feeding direction) and width for communication to its host copier.

## II. SPECIFICATIONS

### A. DADF-C1

Item	Specifications	Remarks
Original pick-up	Circulating, auto duplexing pick-up method	
Original placement 1	Face up	
Original placement 2	Center reference	
Original pick-up	Top pick-up	See p.2-17.
Original type	Sheet (50 to 105 g/m <sup>2</sup> ), single-sided sheet, double-sided sheet	No extra length original.
Original size	A5/STMT to A3/279×432 mm (11"×17")	
Original tray	If small size, 50 sheets, 5.5 mm high max. (A5, B5, B5R, A4, A4R, STMT, LTR, LTRR)	Paper of 80 g/m <sup>2</sup> or less.
	If large size, 25 sheets (B4, A3, LGL, 279×432 mm (11"×17"))	Paper of 80 g/m <sup>2</sup> or less.
Delivery tray	If small size, 50 sheets (A5, B5, B5R, A4, A4R, STMT, LTR, LTRR)	Paper of 80 g/m <sup>2</sup> or less.
	If large size, 25 sheets (B4, A3, LGL, 279×432 mm (11"×17"))	Paper of 80 g/m <sup>2</sup> or less.
Original processing mode	Single-sided, double-sided, reduce image composition	
Original size identification	Length (feeding direction) and width	
Residual original detection	Possible in conjunction with the host copier.	
Continuous feeding	Possible	
Size mix	Possible	Of the same width only.
Communication with copier	IPC 2	
Power supply	24 VDC (from the host copier)	
Maximum power consumption	170 W or less	
Weight	14.8 kg (approx.)	Not including the delivery tray.
Dimensions (mm)	684 (W) × 527 (D) × 161 (H)	Not including the delivery tray.
Serial No.	AB            ZRH    xxxxx INCH/AB    ZRJ    xxxxx A             ZRK    xxxxx INCH/AB    ZRL    xxxxx	
Operating conditions Temperature Humidity	Same as the host copier.	

The above specifications are subject to change for product improvement.

**Table 1-201**

**Note:**

The following must not be used as originals:

- A transparency or paper with an opacity of 80% or less.
- A carbon-backed sheet.
- A sheet with paste-ups or binding.
- A sheet with a cut-off, hole, or tear.
- A sheet with a clip or glue.
- A sheet with curling, wrinkling, or creasing.

**Caution:**

Do not feed the same original more than once to protect against damage.

### III. NAMES OF PARTS

#### A. External View

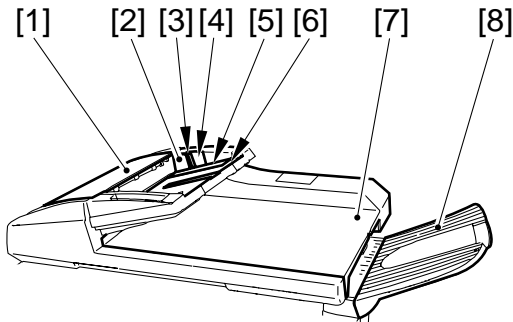

- [1] Upper cover
- [2] Side guide
- [3] Re-circulating guide
- [4] Original Set indicator
- [5] Original tray
- [6] Sub tray
- [7] Body cover
- [8] Original delivery tray

Figure 1-301

#### B. Cross Section

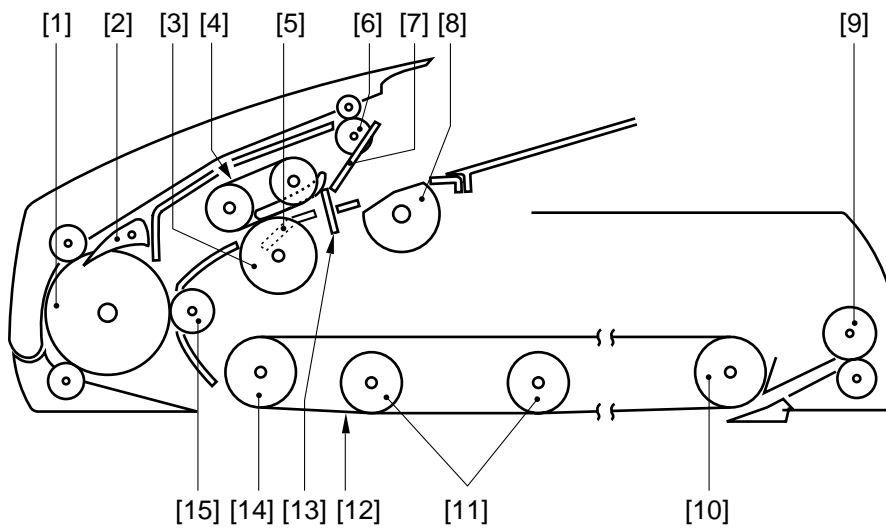

Figure 1-302

- |                            |                               |                                |
|----------------------------|-------------------------------|--------------------------------|
| [1] Reversing roller       | [6] Delivery/pick-up roller   | [11] Retaining rolls           |
| [2] Paper deflecting plate | [7] Paper retaining plate     | [12] Feeding belt              |
| [3] Feeding roller         | [8] Pick-up roller            | [13] Paper stopper plate       |
| [4] Separation belt        | [9] Delivery roller           | [14] Feeding belt drive roller |
| [5] Pre-separation guide   | [10] Feeding belt link roller | [15] Registration roller       |

## IV. OPERATION

### A. Original Set Indicator

The Original Set indicator turns on when an original is placed on the original tray, and flashes when an original jams.

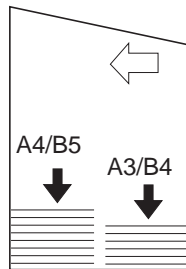

Figure 1-401

#### Operation

- 1) If the original is B5R or larger or is A5 in feeding length, open the original sub tray.
- 2) Set the side guide to suit the size of the original.

#### Reference:

The side guide lock must be removed if the width of the original is larger than 297 mm (A4/A3). For details, see 3. "Side Guide Lock" on p. 3-3.

- 3) Place the originals with the first page on top.
- 4) As needed, set the appropriate copying mode on the copier.
- 5) Press the copier's Copy Start key.

### B. Warnings and Actions

If the Original Set indicator flashes while an original is being fed, suspect a jam and perform the following:

- 1) Remove the originals from the original tray.
- 2) Open the upper cover, and remove the jam. Then, open the DADF to reset the warning. (If any original is on the copyboard glass, remove it.)

#### Caution:

If the jam is in the copier, the copier will run jam recovery mode and will automatically set the originals. Do not open the DADF to reset.

- 3) Set the originals in correct order, and set the stack in the DADF.

## C. Routine Maintenance by the User

Instruct the user to clean the following at least once a week:

### 1. Copyboard Glass

Wipe it with a cloth moistened with water or alcohol; then, dry-wipe it.

### 2. Feeding Belt

Wipe it with water or alcohol.

### 3. Other Parts

Clean all other parts of the DADF (if soiled) using a solution of mild detergent; then, dry-wipe them to remove any residue.

### 4. Feeding Belt and Feeding Roller

Execute cleaning mode in the copier's user mode.



---

# CHAPTER 2

---

## BASIC OPERATION

---

I. BASIC CONSTRUCTION .....	2-1	D. Picking Up Originals .....	2-16
A. Outline of the Electrical Circuitry .....	2-1	E. Reversal .....	2-20
B. Communication with the Copier ..	2-2	F. Reduced Page Composition ...	2-22
C. Inputs to the DADF Controller PCB .....	2-3	G. Delivery .....	2-24
D. Outputs to the DADF Controller PCB .....	2-5	H. Controlling the Pick-Up Motor .	2-27
II. BASIC OPERATION .....	2-6	I. Controlling the Belt Motor .....	2-29
A. Outline .....	2-6	J. Detecting Original Jams .....	2-31
B. Operation .....	2-7	K. Improper Placement of Originals .....	2-34
C. Detecting Originals .....	2-12	III. POWRE SUPPLY .....	2-37
		A. Outline .....	2-37



# I. BASIC CONSTRUCTION

## A. Outline of the Electrical Circuitry

The machine's electrical mechanisms are controlled by the DADF controller PCB. A microprocessor (CPU) is used on the DADF controller PCB, and the microprocessor reads the input signals from the sensors and the copier and generates signals used to drive DC loads (motors, solenoids) at such times as programmed in advance.

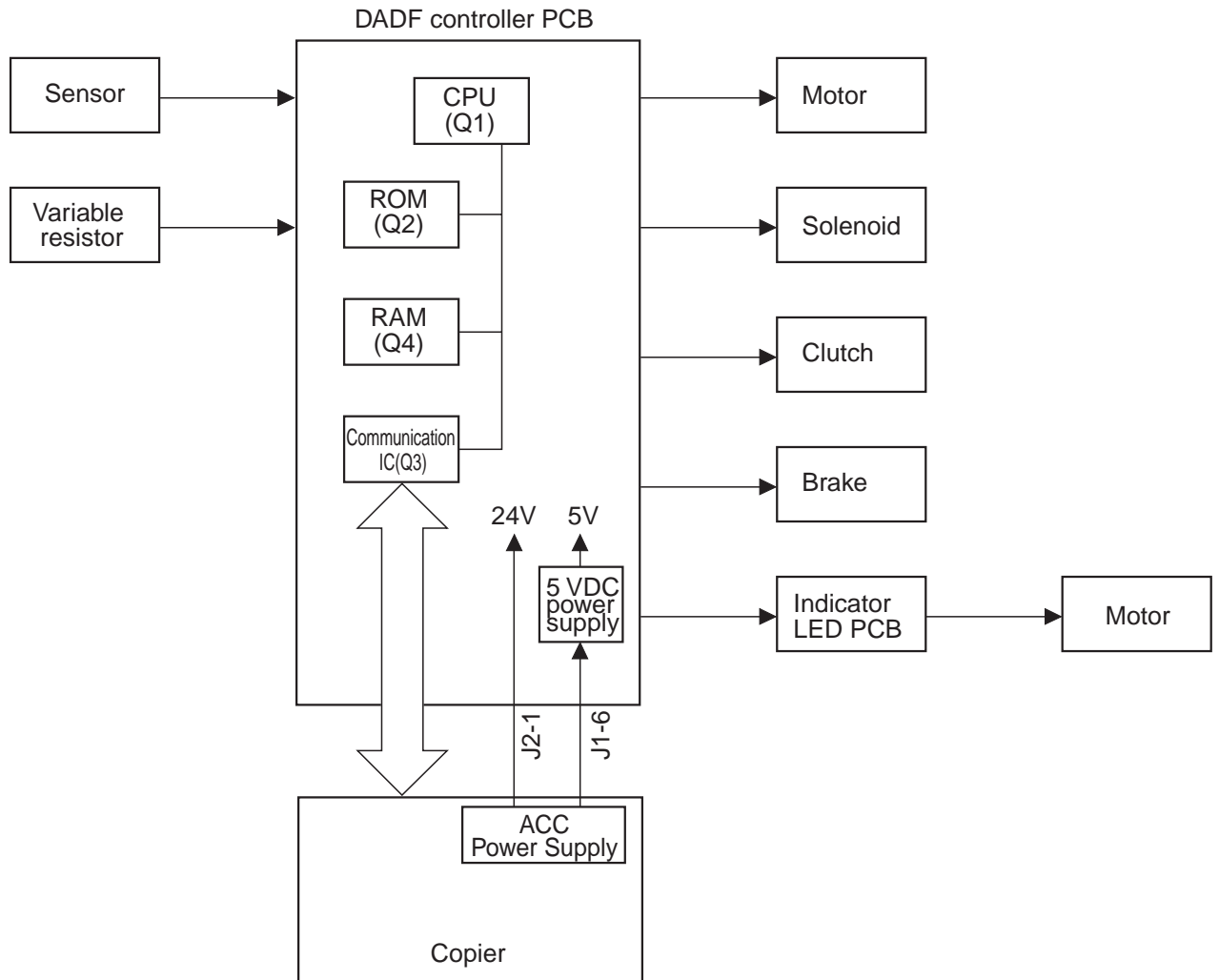

Figure 2-101

## B. Communication with the Copier

The operation modes selected on the copier are communicated to the machine in an IPC communication method. Likewise, the operation states of the machine are communicated to the copier in an IPC communication.

If an error occurs in the IPC communication, the copier's self diagnosis function turns on to indicate "E712" on its control panel.

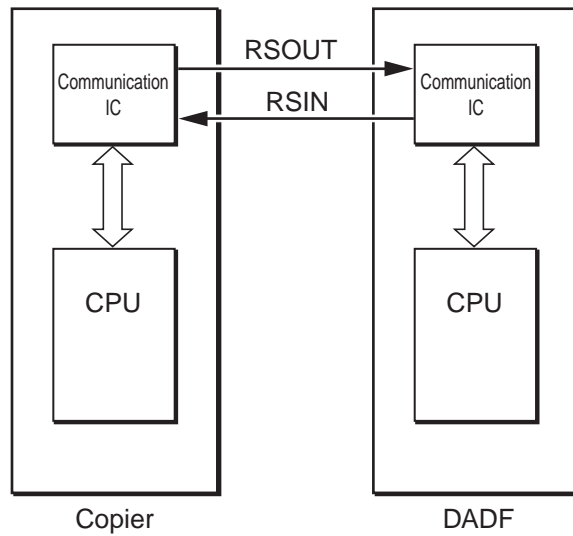

Figure 2-102

### C. Inputs to the DADF Controller PCB

#### Inputs to the DADF Controller PCB (1/2)

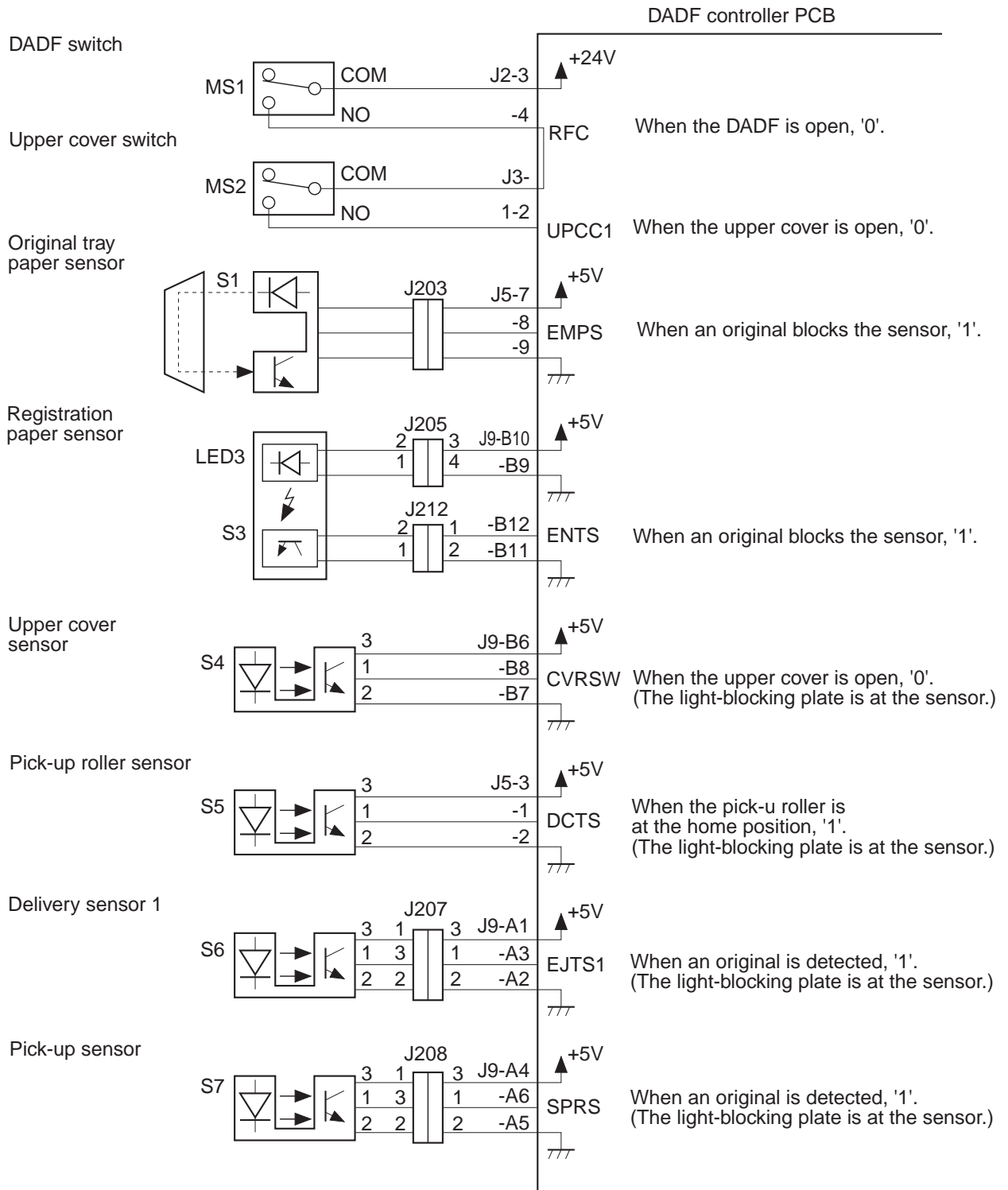

Figure 2-103

Inputs to the DADF Controller PCB (2/2)

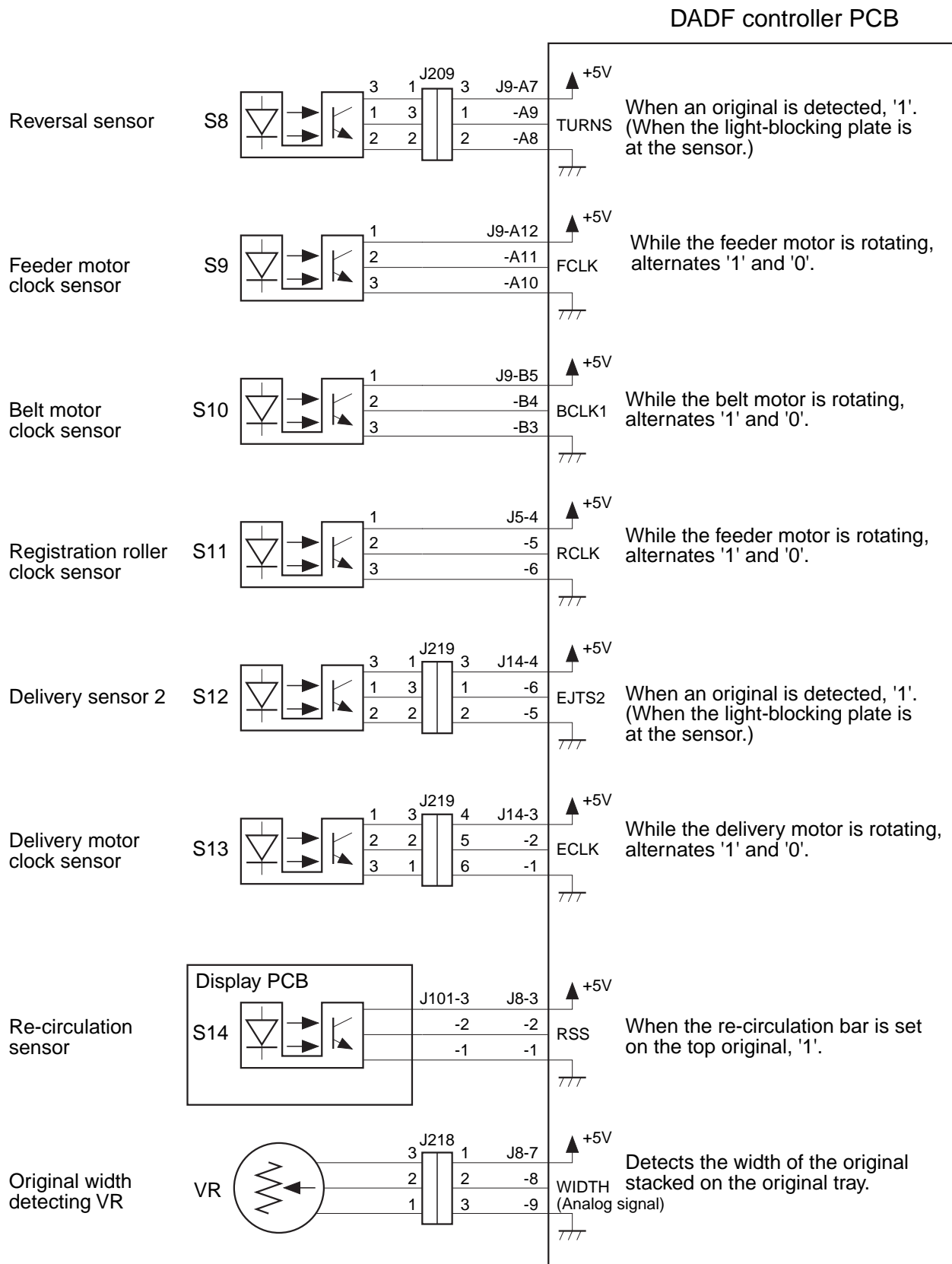

Figure 2-104

## D. Outputs to the DADF Controller PCB

### Outputs to the DADF Controller PCB (1/1)

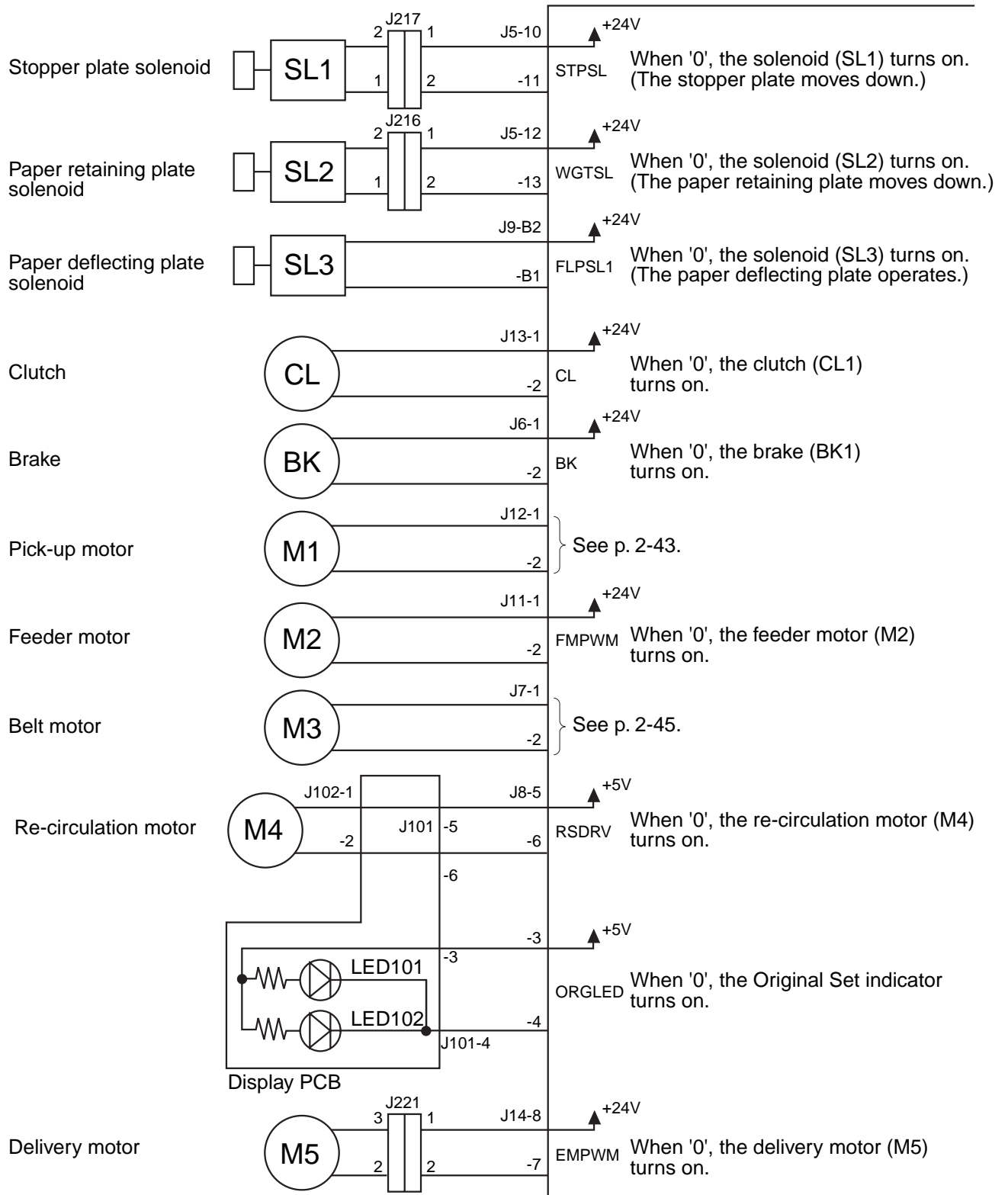

Figure 2-105

## II. BASIC OPERATION

### A. Outline

The machine uses four motors and one clutch to pick up, feed, and deliver originals.

The pick-up motor (M1) serves to pick up originals. The feeder motor (M2) serves to reverse and deliver originals. The belt motor (M3) moves and stops originals to and on the copyboard glass, and delivers them. The delivery motor (M3) operates to deliver originals to the delivery tray.

The clutch (CL) is used to engage or disengage the drive of the feeder motor (M2) and the belt motor (M3).

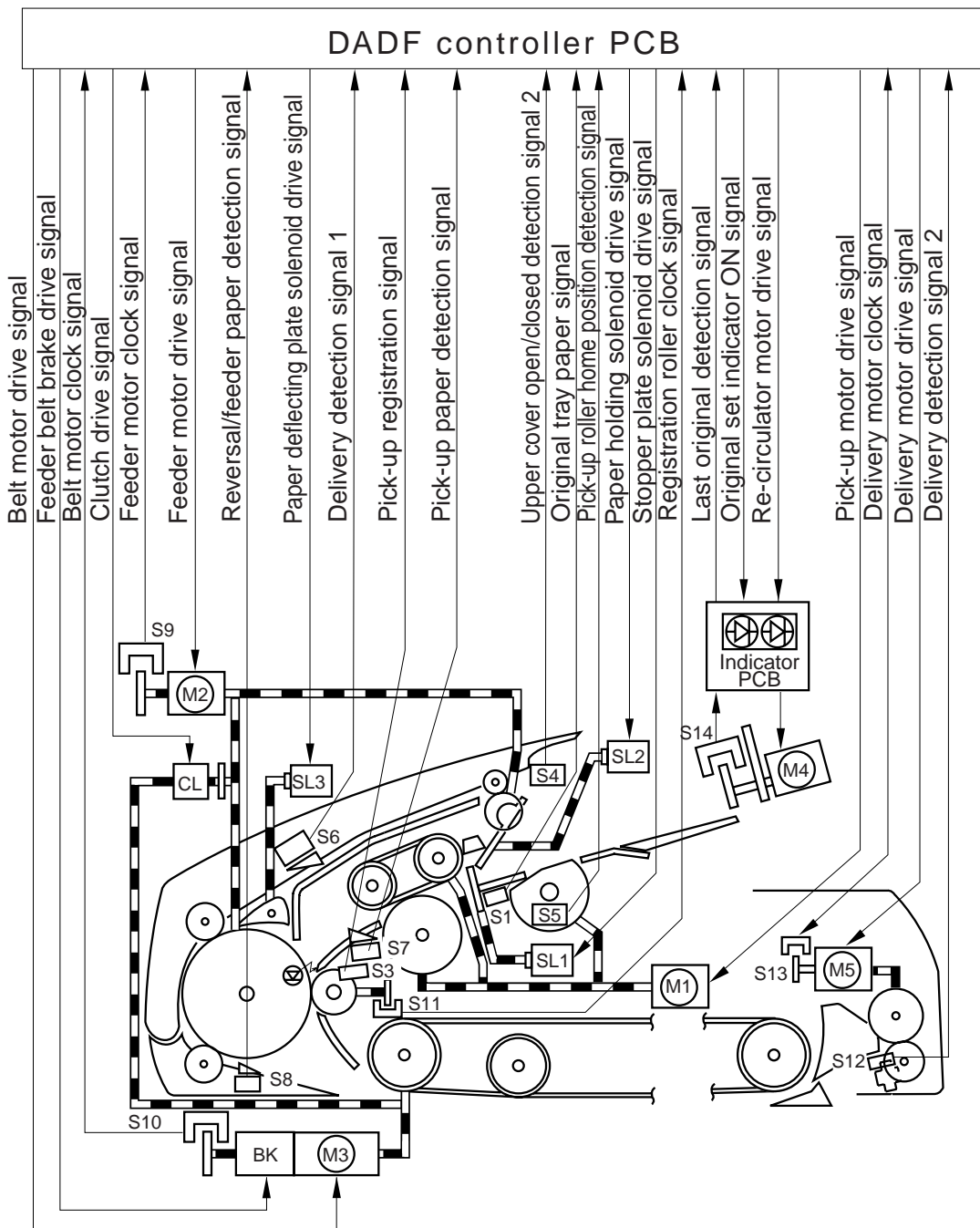

Figure 2-201



## B. Operation

The machine enables the following five operations:

1. Double-sided original to single-sided copy
2. 2 small-size originals to reduced page composition
3. Single-sided original to double-sided copy
4. Double-sided original to double-sided copy  
Using auto duplexing unit.
5. Top pick-up mode original feeding  
The machine feeds originals in any of the following three ways according to the instructions from the copier:

**1. Double-Sided Original Mode**

When copying the face (1st side) and the back (2nd side) of an original, the machine automatically reverses the original.

- a. Reverse the original → Copies the 2nd side. → Copies the 1st side. → Delivers the original.

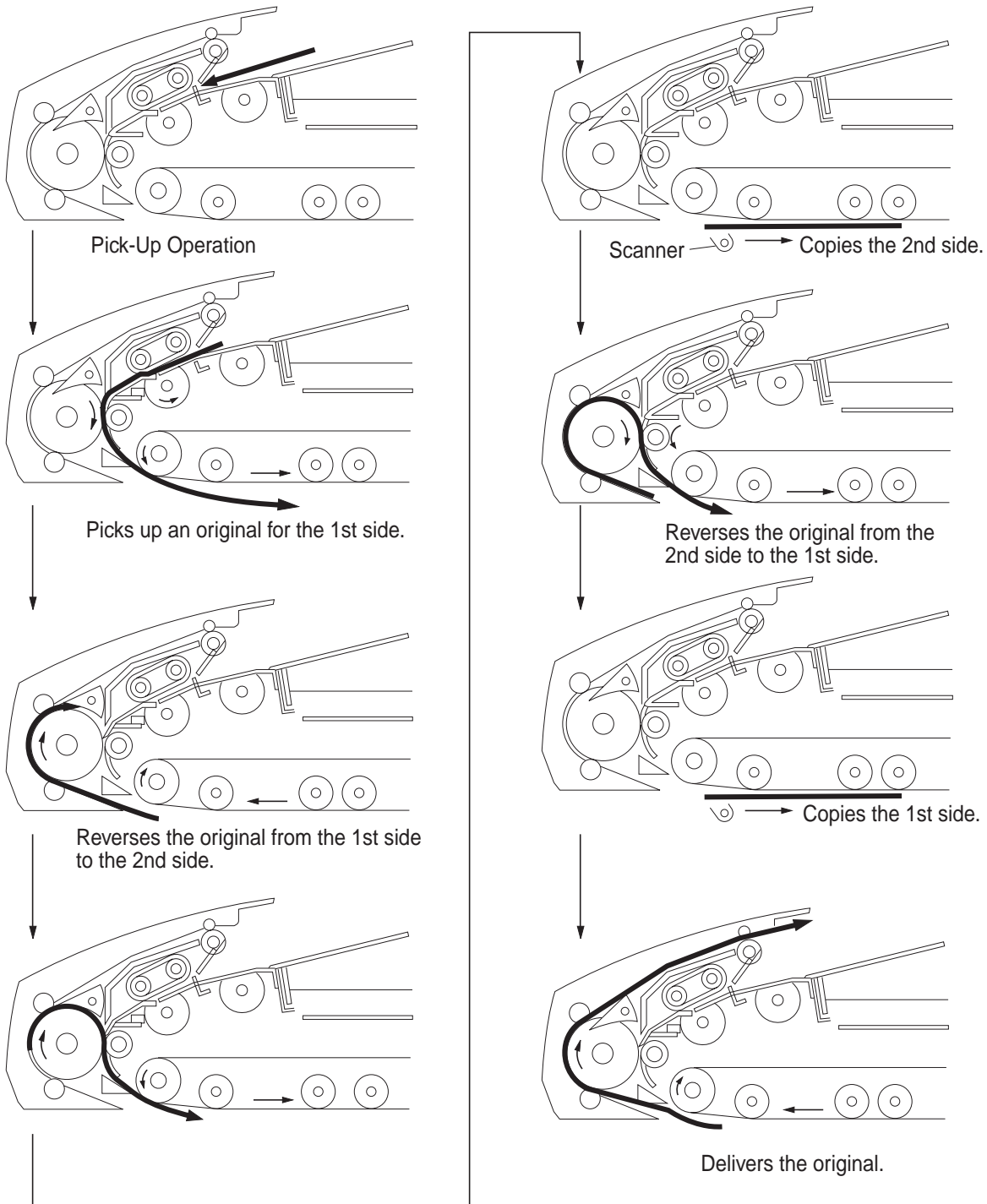

Figure 2-202

- b. Copies the 1st side → Copies the 2nd side → Reverse the original. → Delivers the original.

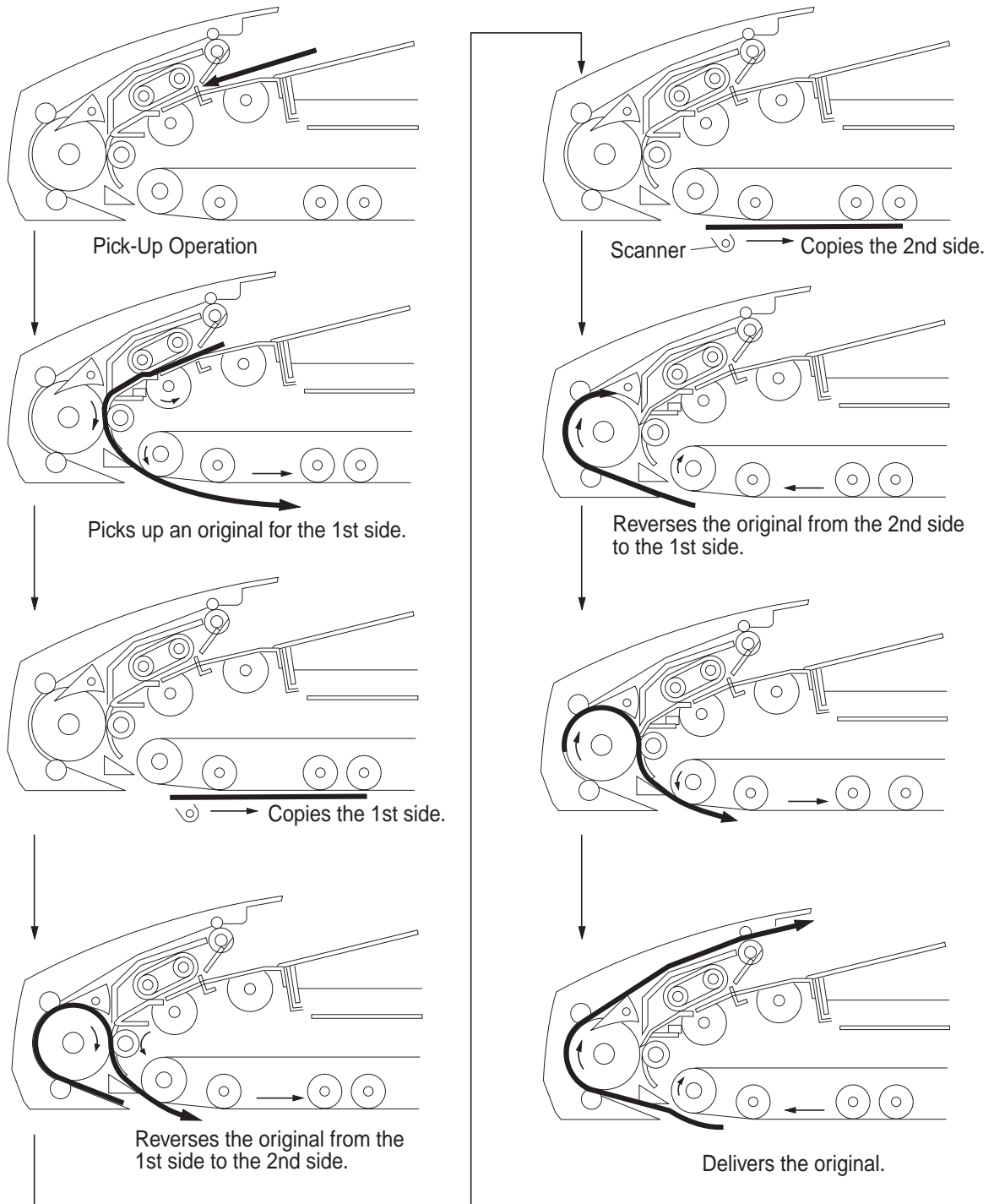

Figure 2-203

## 2. Reduced Page Composition Mode

When reducing and copying two originals in page composition mode, the machine automatically picks up two originals and places them on the copyboard glass side by side. Table 2-201 shows the sizes of originals that may be used in the machine.

A/B-configured	Inch-configured
A5	STMT
B5	LTR
A4	

Table 2-201

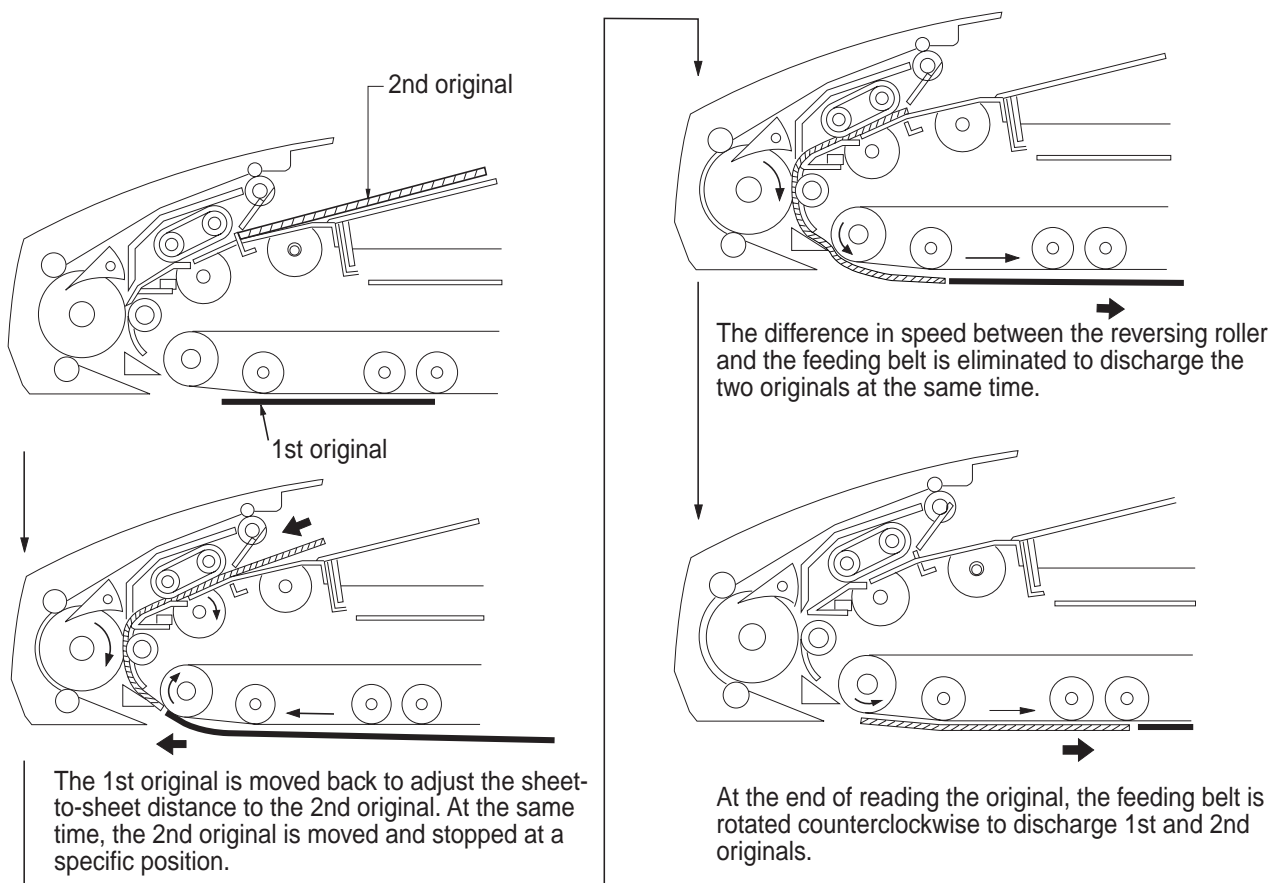

Figure 2-204

### 3. Top Pick-Up Feeding

The machine picks up the originals on the original tray from the top (first page of the stack), and places them on the copyboard glass.

Each time an original has been read, the machine moves the original from the copyboard glass to the original delivery tray.

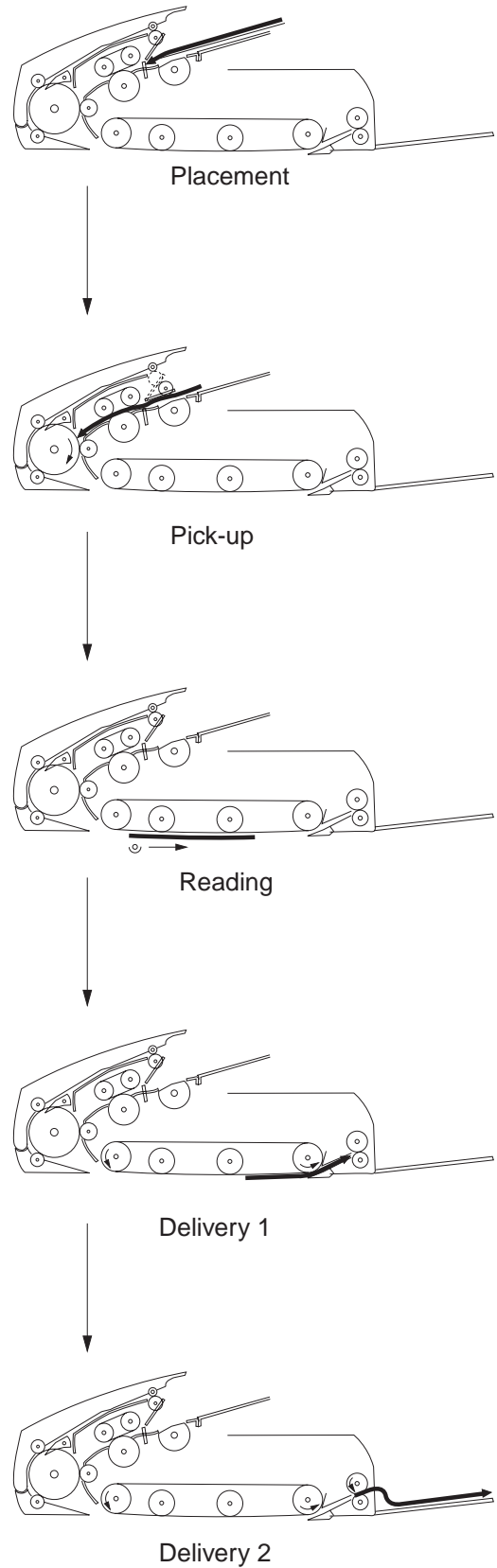

Figure 2-205

## C. Detecting Originals

### 1. Outline

The machine has the following four types of document detection:

1. Detects the presence/absence of an original on the original tray.
2. Detects the size of originals place on the original tray.
3. Detects the number of originals that have been copied.
4. Detects the trailing edge of the last original.

### 2. Detecting the Presence/Absence of an Original

The presence/absence of an original on the original tray is detected by the original tray paper sensor (PS1).

When an original is set on the original tray, the light between the original tray paper sensor (S1) and the prism is blocked, causing the original tray paper sensor (S1) to generate the original detection signal (EMPS).

In response to the original detection signal (EMPS), the DADF controller PCB turns on the Original Set indicator (LED101, LED102).

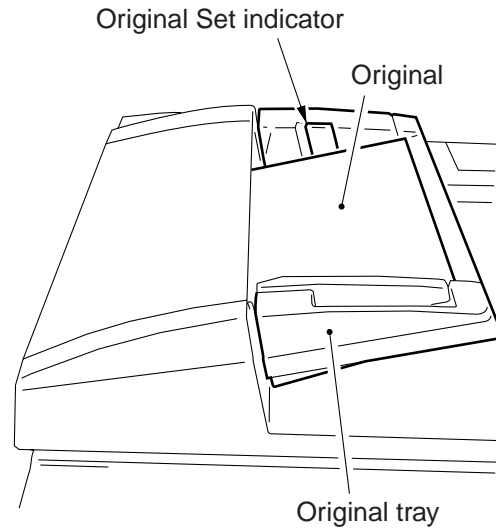

Figure 2-207

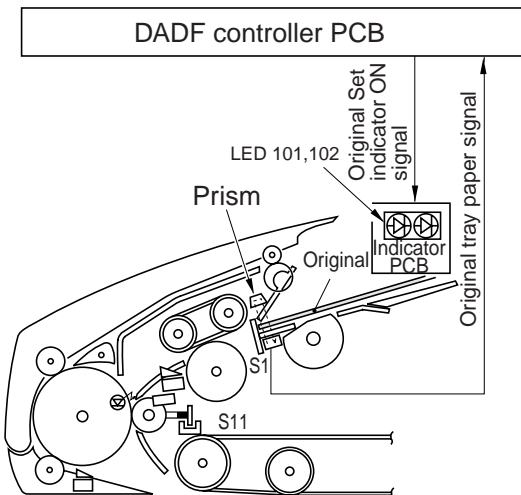

Figure 2-206

**3. Detecting the Size of an Original**

**a. Outline**

The machine detects the size of an original in relation to the vertical (feeding) and horizontal directions of the original, ensuring correct size detection.

**b. Detecting in Vertical (feeding) Direction**

Detection in vertical direction is made by the registration paper sensor (S3) and the registration roller clock sensor (S11).

The registration paper sensor detects the leading and trailing edges of an original, and the registration roller clock sensor detects the rotation of the registration roller while the original moves past the sensor. The rotation of the registration roller is converted to the length of the original.

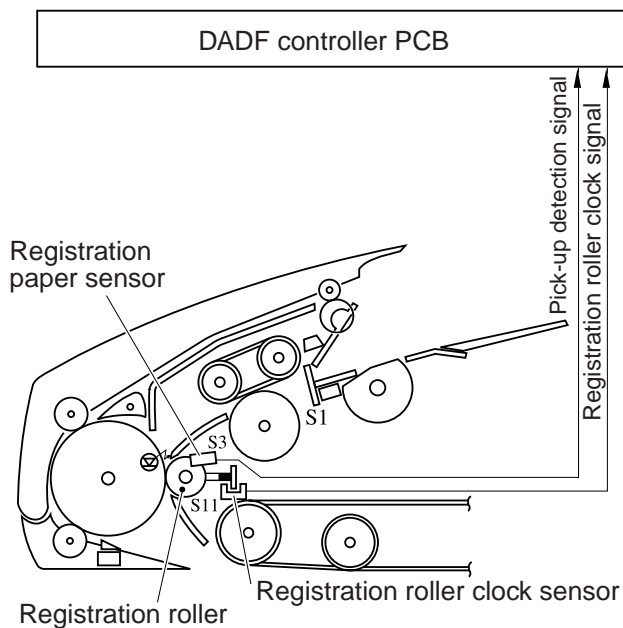

**Figure 2-208**

**c. Detection in Horizontal Direction**

Detection in horizontal direction is made by the original width detecting volume (VR) on the original tray. The original width detecting volume operates in conjunction with the side guide. As its resistance varies, the changes are detected by the DADF controller PCB, which converts them into a length in horizontal direction.

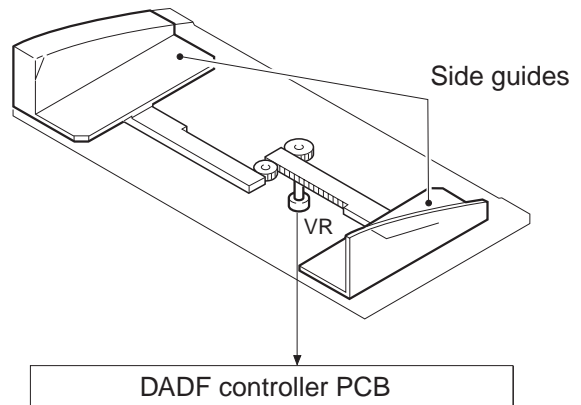

**Figure 2-209**

The copier identifies the size of an original in terms of a default size based on the results of vertical and horizontal lengths communicated by the machine.

Table 2-202 shows the default sizes that are identified:

d. A Model, A/B Model

Default	Vertical length	Original width
B5R	257mm	177~187mm
A5	148.5mm	205~215mm
A4R	330mm	
FOOLSCAP	330mm	
B5	182mm	252~262mm
B4	364mm	
COMPUTER paper	381mm	274~284mm
A4	210mm	292~302mm
A3	420mm	

For vertical direction, a deviation of  $\pm 10$  mm is ignored; for horizontal direction, a deviation of  $\pm 5$  mm is ignored; outside the ranges, the original will be identified as being of a non-default size.

**Table 2-202**

e. Inch Model

Default	Original length	Original width
STMT	140mm	211~221mm
LTRR	279mm	
FOOLSCAP	330mm	
LGL	356mm	
LTR	216mm	274~284m
COMPUTER paper	381mm	
297mm×432mm (11"×17")	432mm	

In vertical direction, a deviation of  $\pm 10$  mm is ignored; in horizontal direction, a deviation of  $\pm 5$  mm is ignored; outside the ranges, the original will be identified as being of a non-default size.

**Table 2-203**

f. Inch Model and Inch/AB Model

Default	Original length	Original width
B5R	257mm	177~187mm
A5	148mm	205~213mm
A4R	297mm	
STMT	140mm	214~221mm
LTRR	279mm	
FOOLSCAP	330mm	
LGL	356mm	
B5	182mm	252~262mm
B4	364mm	
LTR	216mm	274~284mm
COMPUTER paper	381mm	
279mm×432mm (11"×17")	432mm	
A4	210mm	
A3	420mm	

For original length, a deviation of  $\pm 10$  mm is ignored; for original width, a deviation of  $\pm 5$  mm is ignored; outside the ranges, the original will be identified as being of a non-default size.

**Table 2-204**



#### 4. Detecting the Trailing Edge of the Last Original

A copier with a long paper path (from the cassette to the drum) is designed to pick up copy paper early to speed up copying work. As such, when the machine picks up the last original and places it on the copyboard glass, the next paper is likely to be kept in wait.

To accommodate this, the machine is designed to pick up originals to suit the timing at which its host copier picks up copy paper.

If the length of an original is 220 mm or less, the machine sets the first original on the copyboard glass, and moves the second original beyond the registration roller.

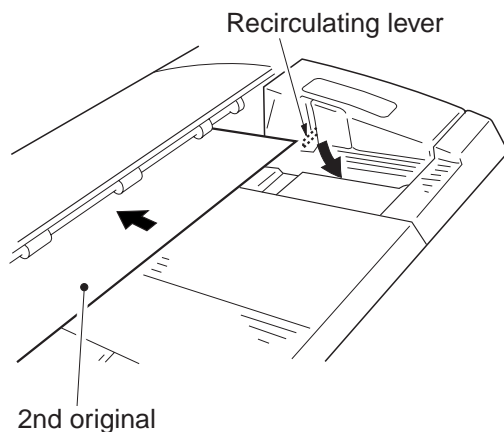

**Figure 2-210**

If the re-circulating lever is on the original tray in this condition, the machine communicates to the copier that the third and subsequent originals are present, and the copier picks up copy paper for the next copying run.

When the re-circulating lever has dropped on the original tray, the machine communicates to the copier that there is not third or subsequent originals (RSS signal) so that the copier will not pick up copy paper.

## D. Picking Up Originals

### 1. Outline

The machine uses top pick-up mode (i.e., top separation, in which the topmost sheet of the stack of originals is picked up first); in other words, the first page will be picked up first. See the following diagram for the construction of the pick-up assembly.

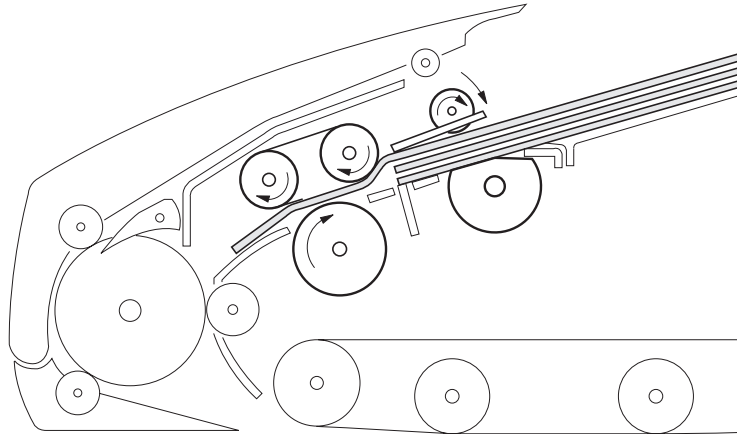

Top pick-up mode

**Figure 2-211**

When the pick-up motor starts to rotate counterclockwise, the arm on the pick-up roller shaft transmits its drive to the original guide and the switching arm. In response, the original guide moves downward. On the other hand, the rear and the front of the separation belt operating in connection with the switching arm move upward to start top pick-up mode.

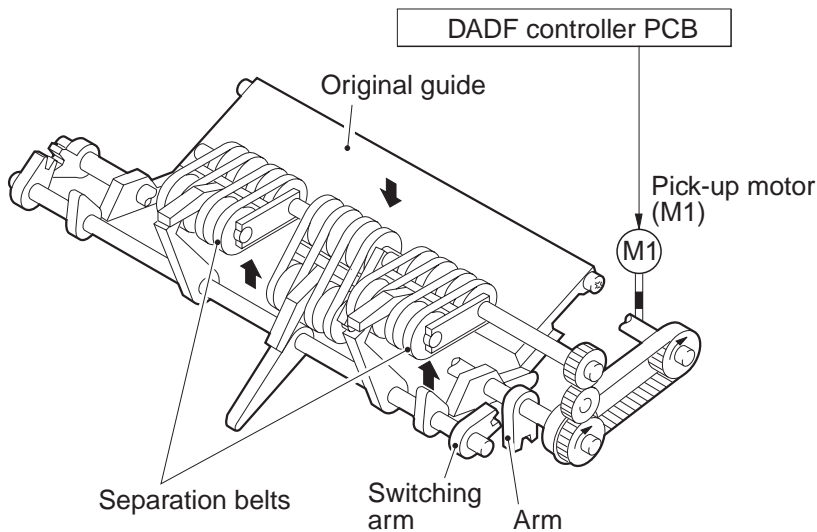

**Figure 2-212 Top Separation Mode**

**2. Top Pick-Up Mode**

**a. Operation**

When top pick-up mode is executed with originals on the original tray, the following will take place:

**1) Pick-Up Separation**

The paper stop plate is brought down, and the paper retaining plate is moved down to the stack of originals; then, the first page of the stack is picked up.

After pick-up, the original is fed between the separation belt and the feeding roller to prevent double feeding. (The direction of rotation of the separation belt and the feeding roller is the opposite of the direction in bottom pick-up mode.)

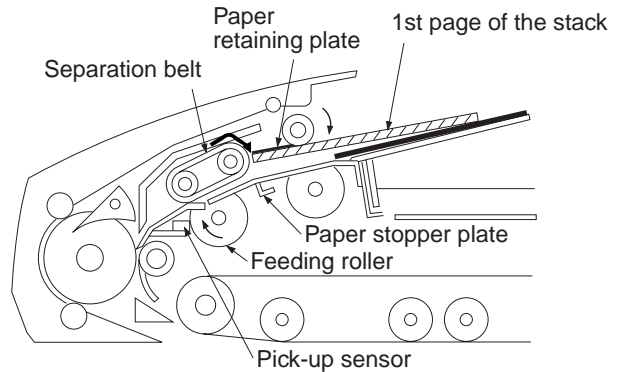

**Figure 2-213**

**2) Arching**

The original is butted against the registration roller so that it arches.

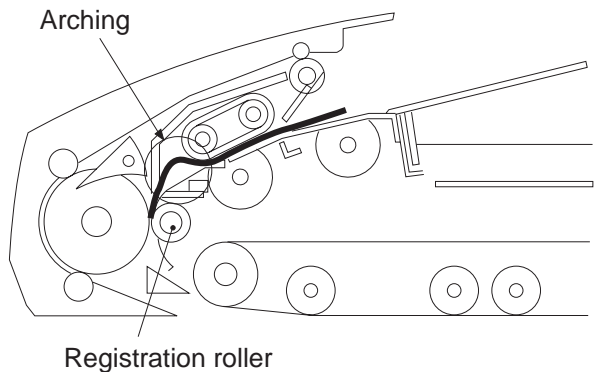

**Figure 2-214**

3) Feeding

The feeding belt, registration roller, and feeding roller are rotated to move the original to the copyboard glass.

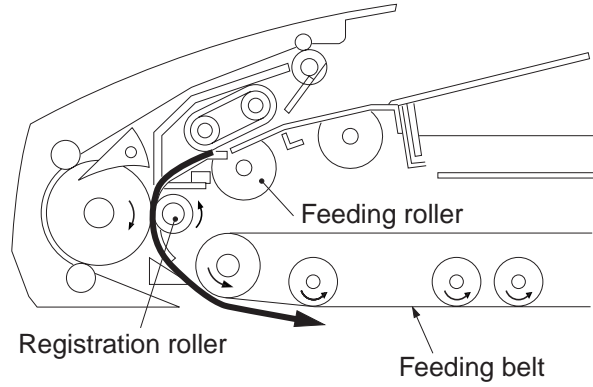

Figure 2-215

4) Picking Up the 2nd Original

When the original reaches a specific position on the copyboard glass, the copier's scanner starts to move forward. At the same time, the 2nd original is picked up (if of small size). In the case of a large-size original, the 2nd original is picked up after delivery of the first original.

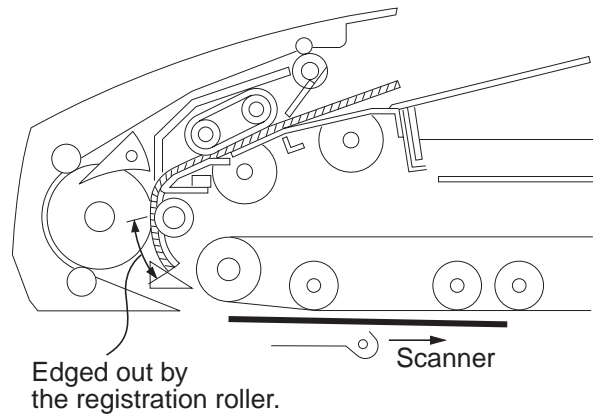
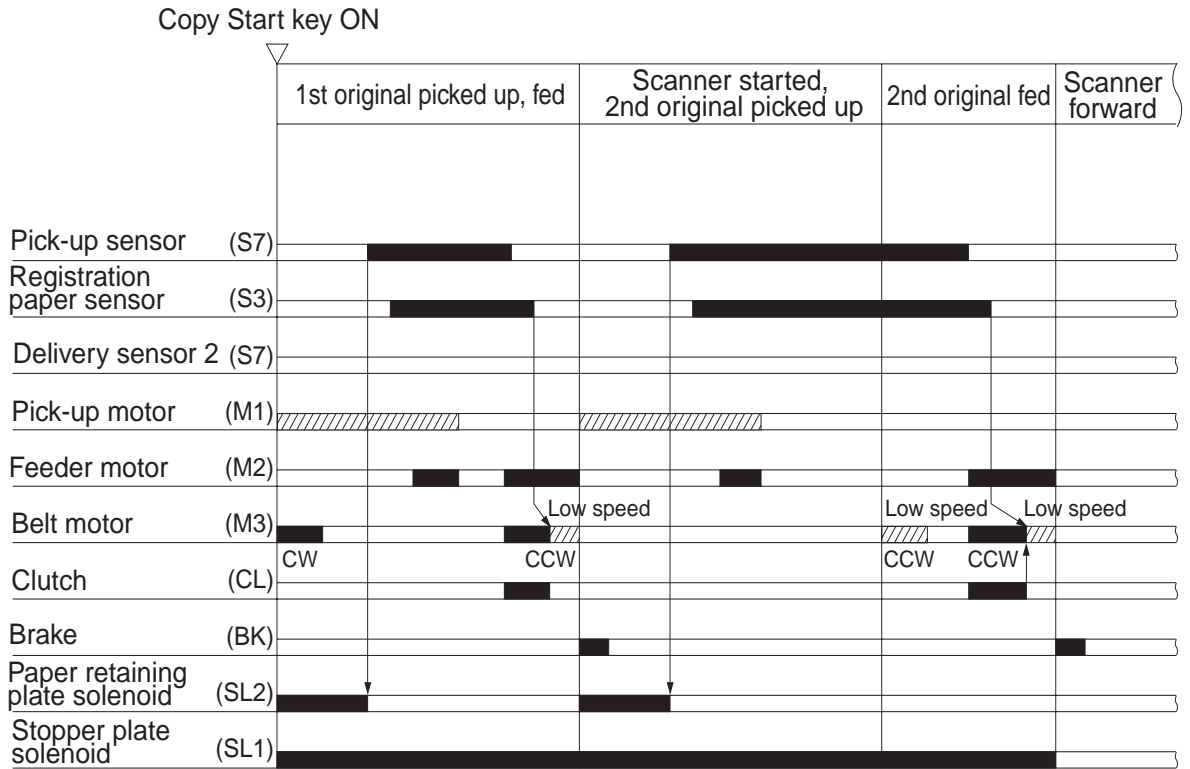

Figure 2-216

b. Sequence of Operations (A4, 2 originals, top pick-up mode)



: The pick-up motor rotates in the direction opposite to the direction in copying mode.  
 CW : The feeding belt rotates clockwise.  
 CCW : The feeding belt rotates counterclockwise.

Figure 2-217

## E. Reversal

### 1. Operation

Reversal may be either from the first side to the second side, or from the second side to the first side. (Since the same mechanism is involved, the discussions herein will be on reversal from the first side to the second side.)

#### 1) Picking Up for the 1st Side

An original is moved from the original tray to the copyboard glass.

#### 2) Reversal/Feeding

The feeding belt is rotated counterclockwise to reverse/feed the original on the copyboard glass.

#### 3) Reversal/Delivery Switching

The paper deflecting solenoid (SL3) is turned on to open the paper deflecting plate so that the original is moved back to the copyboard glass, reversing the original.

When the second side of the original is set on the copyboard glass, the scanner starts to move forward.

While the scanner is moving in reverse, the original is reversed once again so that its first side is set on the copyboard glass. When the 1st side of the original has been copied, the original is moved for delivery.

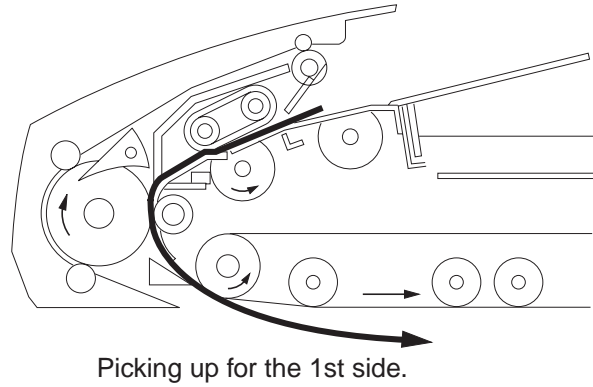

Figure 2-218

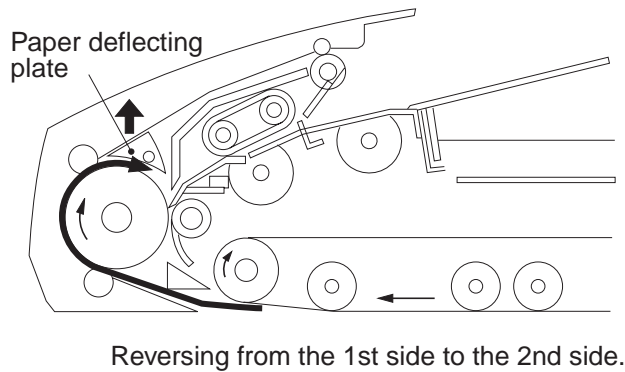

Figure 2-219

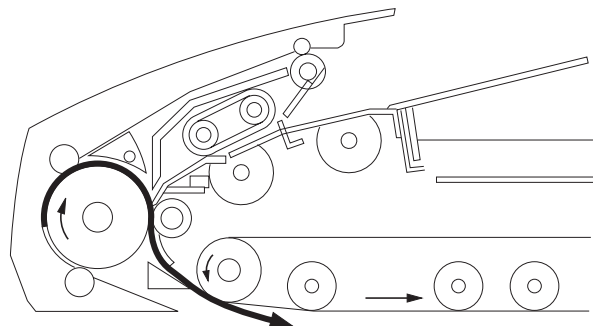

Figure 2-220

2. Sequence of Operations (reversal)

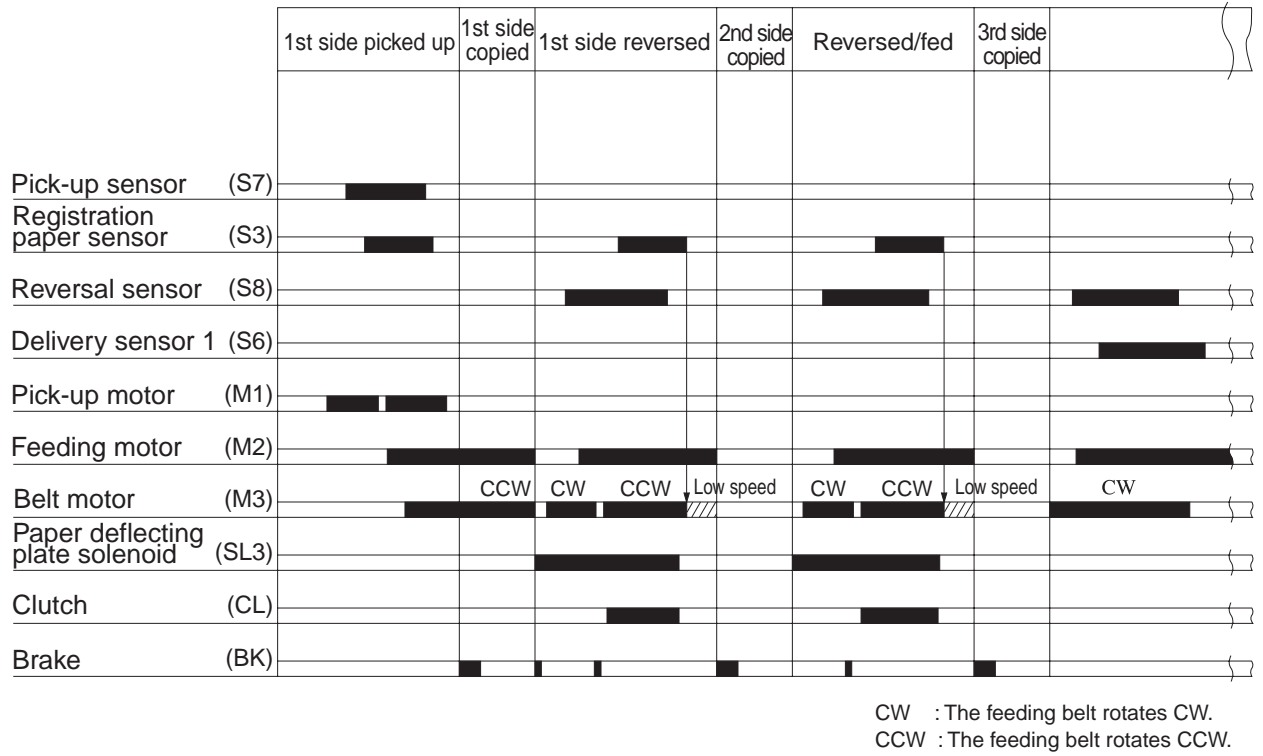

Figure 2-221

## F. Reduced Page Composition

### 1. Top Pick-Up Mode

In top pick-up mode, the originals are picked up starting with the top sheet, not requiring reordering of the originals.

#### 1) Picking Up the 1st Side

The 1st original is picked up and stopped on the copyboard glass. For details of pick-up operation, see D-2 “Top Pick-UP” on p. 2-17.

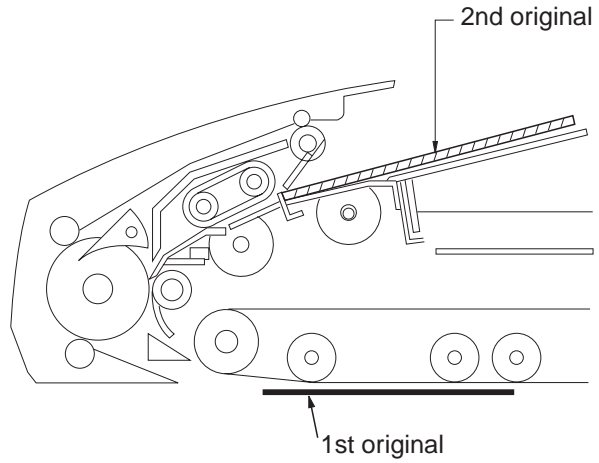

Figure 2-222

#### 2) Positioning the 1st Side Original/Feeding the 2nd Side Original

The 1st original is moved back to adjust the sheet-to-sheet distance. Further, two originals are moved simultaneously and stopped at specific positions.

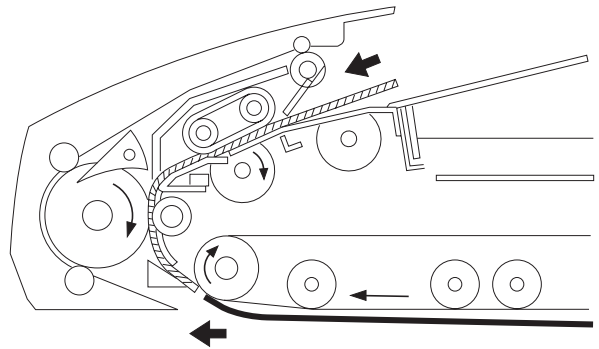

Figure 2-223

#### 3) Feeding the 1st Side and 2nd Side Originals Simultaneously

The clutch (CL) is turned on to eliminate the difference in speed between the delivery/reversing roller and the feeding belt, and two originals are fed simultaneously.

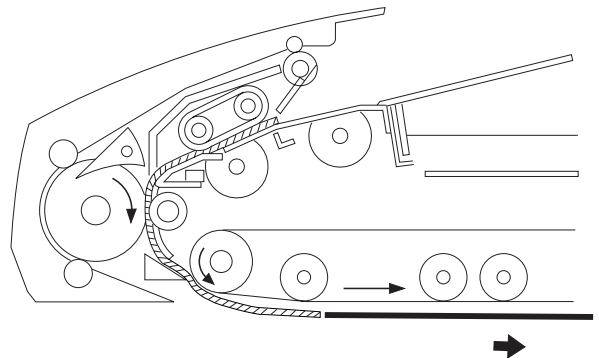

Figure 2-224



- 4) Delivering the 1st and 2nd Originals  
 When the original has been read, the feeding belt is rotated counterclockwise, and the 1st and 2nd originals are delivered.  
 If there are 3rd and 4th originals, pick-up is started.

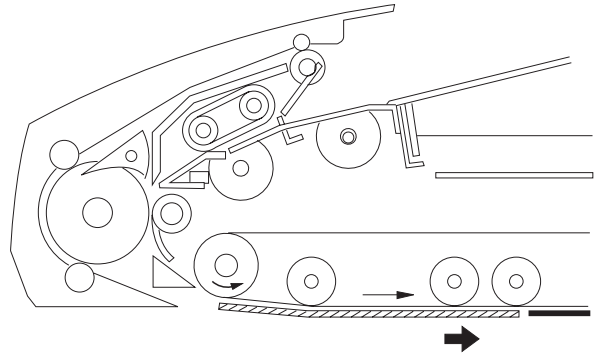

Figure 2-225

2. Sequence of Operations (reduced page composition; top pick-up)

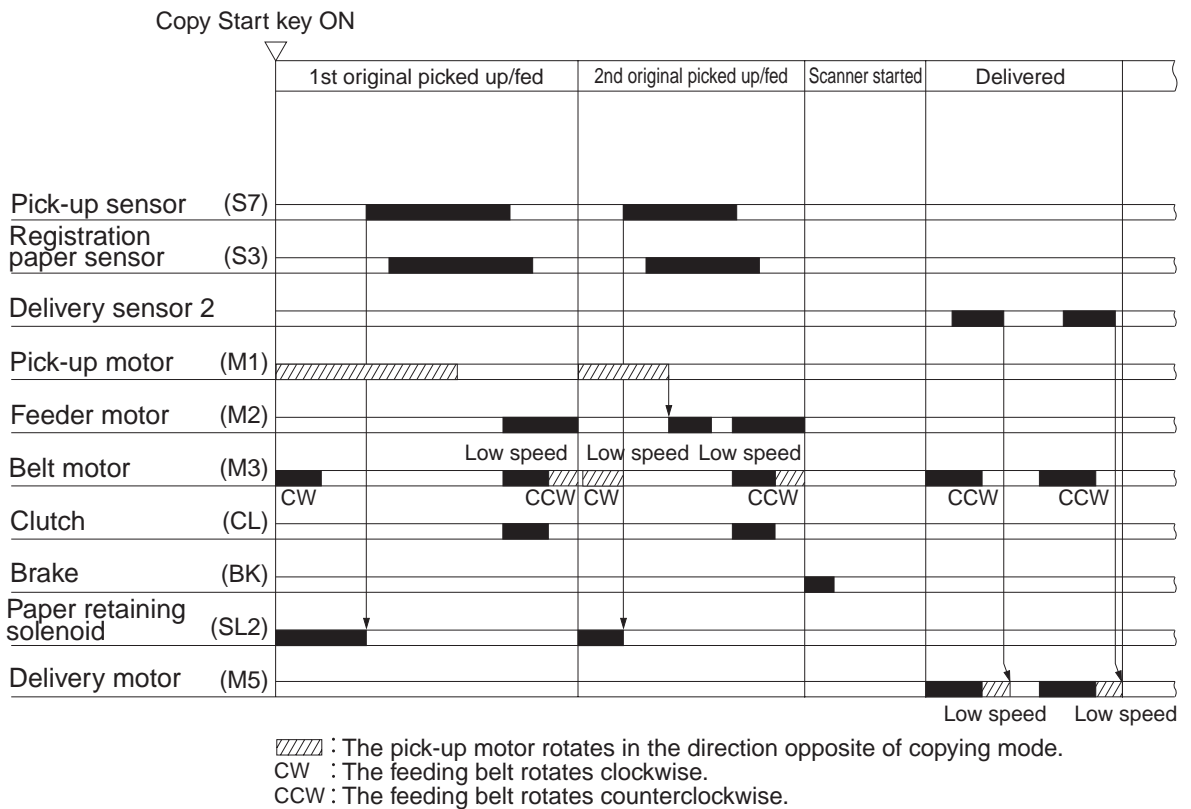
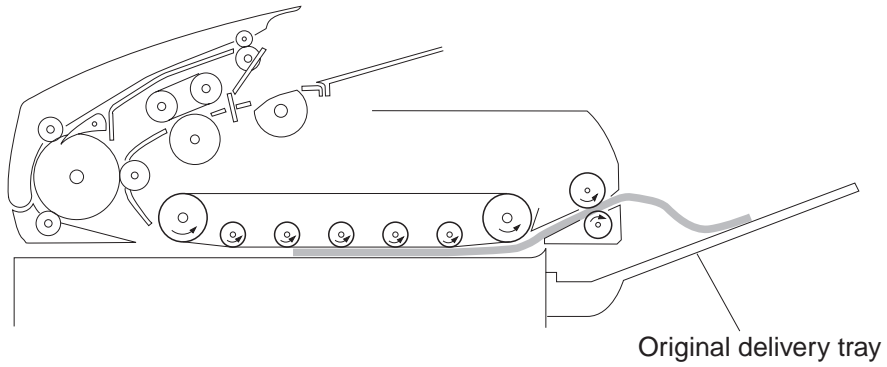

Figure 2-226

## G. Delivery

### 1. Outline

The machine discharges originals to the original delivery tray.



**Figure 2-227**  
**Top Pick-up mode**

**2. Top Pick-Up Mode Delivery**

**a. Operation**

The machine delivers the original on the copyboard tray as follows:

**1) Feeding the 1st Original**

The feeding belt is rotated counterclockwise to feed the 1st original about 30 mm (to maintain the sheet-to-sheet distance from the 2nd original).

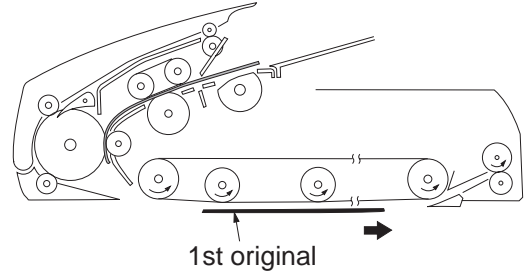

**Figure 2-228**

**2) Delivering the 1st Original/Picking Up the 2nd Original**

The clutch (CL) is turned on to eliminate the difference in speed between the delivery/reversing roller and the feeding belt; the 1st original is moved for delivery, and the 2nd original is picked up.

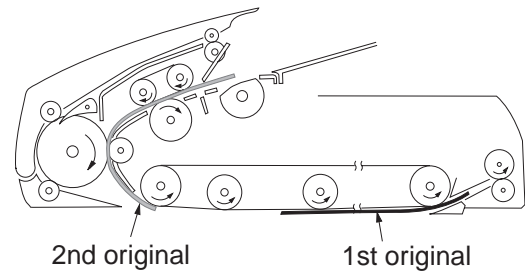

**Figure 2-229**

**3) Delivery to the Original Delivery Tray**

While the trailing edge of the original is moved to the original delivery tray, the delivery motor (M5) switches to low speed to deliver the original slowly.

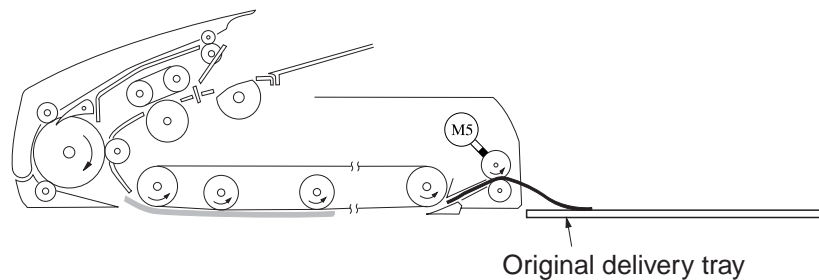

**Figure 2-230**

b. Sequence of Operations (small size, pick-up/delivery)

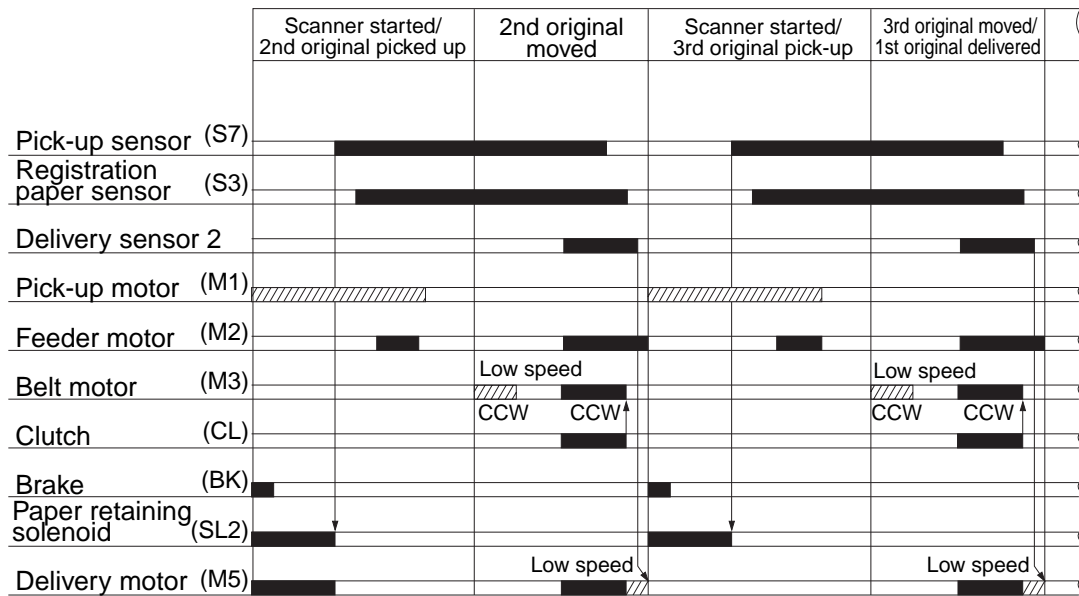

[Hatched] : The pick-up motor rotates in the position opposite of copying mode.  
 CW : The feeding belt rotates clockwise.  
 CWW : The feeding belt rotates counterclockwise.

Figure 2-231

## H. Controlling the Pick-Up Motor

### 1. Outline

Figure 2-267 is a block diagram of the pick-up motor.

The feeder motor is a DC motor. The microprocessor (Q1) on the DADF controller PCB sends to the drive circuit the pick-up motor drive signal (SMON), pick-up motor rotation direction signal (SDIR), and pick-up motor rotation speed control signal (SMPWM).

In response, the drive circuit drives the pick-up motor according to these three signals.

The control circuit is not equipped with a circuit used to provide the microprocessor (Q1) with feed back, indicating the state of pick-up rotation. As such, the pick-up motor rotation speed control signal (SMPWM) remains constant at all times, and no correction is made when the rotation speed of the pick-up motor fluctuates because of an external force.

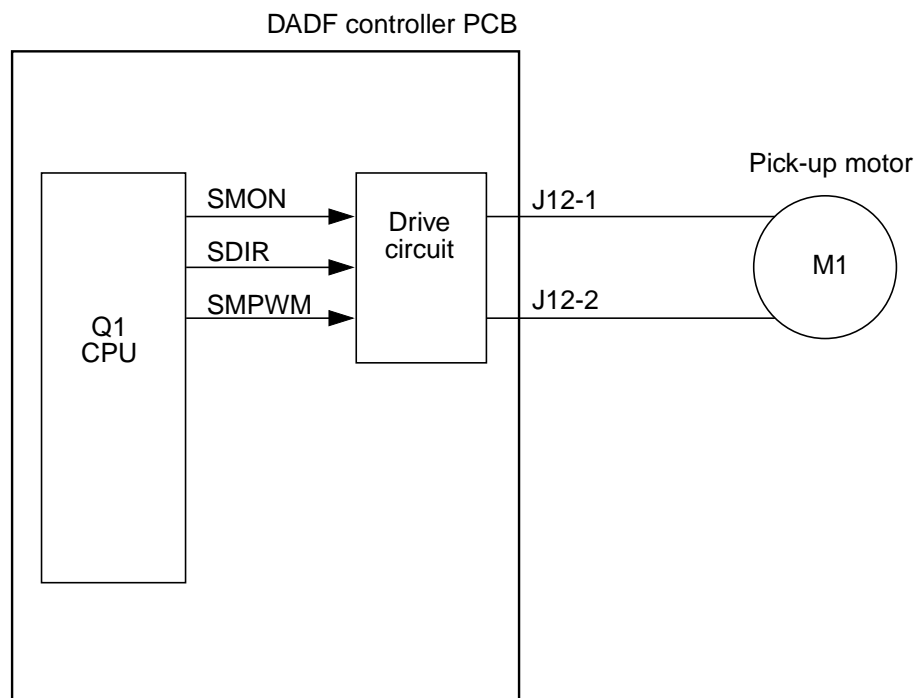

Figure 2-232

**2. Relationship Between the Pick-UP Motor Drive Signal (SMON), Pick-Up Motor Rotation Direction Signal (SDIR), and Pick-Up Motor Rotation Speed Control Signal (SMPWM) and the Operation of the Pick-Up Roller**

Belt motor drive signal (SMON)	Belt motor rotation direction signal(SDIR)	Belt motor rotation speed control signal (SMPWM)	Pick-up roller operation
"1"	"1"	Pulses	The pick-up roller rotates in copier mode pick-up direction (counterclockwise).
"1"	"1"	"0"	The pick-upper roll rotates by inertia in copier mode pick-up direction.
"1"	"0"	Pulses	The pick-up roll rotates in fax mode pick-up direction (clockwise).
"1"	"0"	"0"	The pick-upper roller rotates by inertia in fax mode pick-up direction (clockwise).c
"0"	"1" / "0"	"1" / "0"	The pick-up roller stops.

**Table 2-205**

## I. Controlling the Belt Motor

### 1. Outline

Figure 2-268 is an outline diagram of the belt motor control circuit.

The belt motor is a DC motor.

The microprocessor (Q1) on the DADF controller PCB sends the belt motor drive signal (BMON), belt motor rotation direction signal (BDIR), and belt motor rotation speed control signal (BMPWM) to the drive circuit.

When the belt motor starts to rotate, the belt motor clock sensor (S10) sends the belt motor clock signal (BCLK1) to the microprocessor (Q1). In response, the microprocessor (Q1) compares the belt motor clock signal (BCLK1) against the rotation speed stored in memory to vary the belt motor rotation speed control signal (PMPWM) to make a match, causing the belt motor (M3) to rotate at a specific speed at all times.

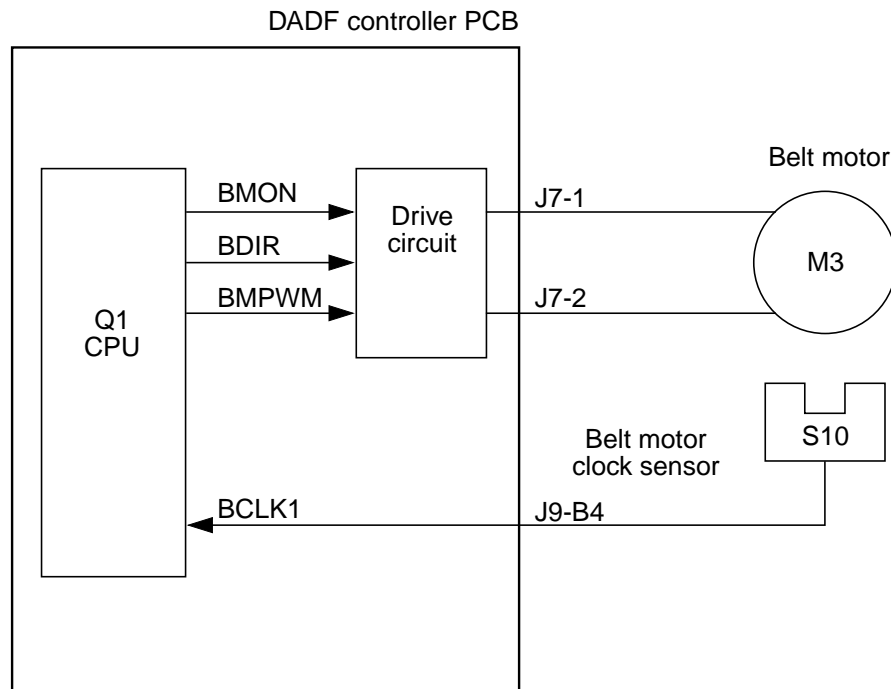

Figure 2-233

**2. Relationship Between the Belt Motor Drive Signal (BMON), Belt Motor Rotation Direction Signal (BDIR), and Belt Motor Rotation Speed Control Signal (BMPWM) and the Feeding Belt**

Belt motor drive signal (BMON)	Belt motor rotation direction signal(BDIR)	Belt motor rotation speed control signal (BMPWM)	Feeding Belt
"1"	"1"	Pulses	The feeding belt rotates in pick-up direction (counterclockwise).
"1"	"1"	"0"	The feeding belt rotates by inertial in pick-up direction (counterclockwise).
"1"	"0"	Pulses	The feeding belt rotates in copier mode delivery direction (clockwise).
"1"	"0"	"0"	The feeding belt rotates by inertial in copier mode delivery direction(clockwise).
"0"	"1" / "0"	"1" / "0"	The feeding belt stops.

**Table 2-206**

**3. Protecting the Belt Motor from Overcurrent**

At times, overcurrent can occur because of a specific type of original or state of the machine. To protect the power supply circuit from extra loads occurring because of continuing overcurrent while the belt is rotating in pick-up direction, an overcurrent control circuit is provided.



## J. Detecting Original Jams

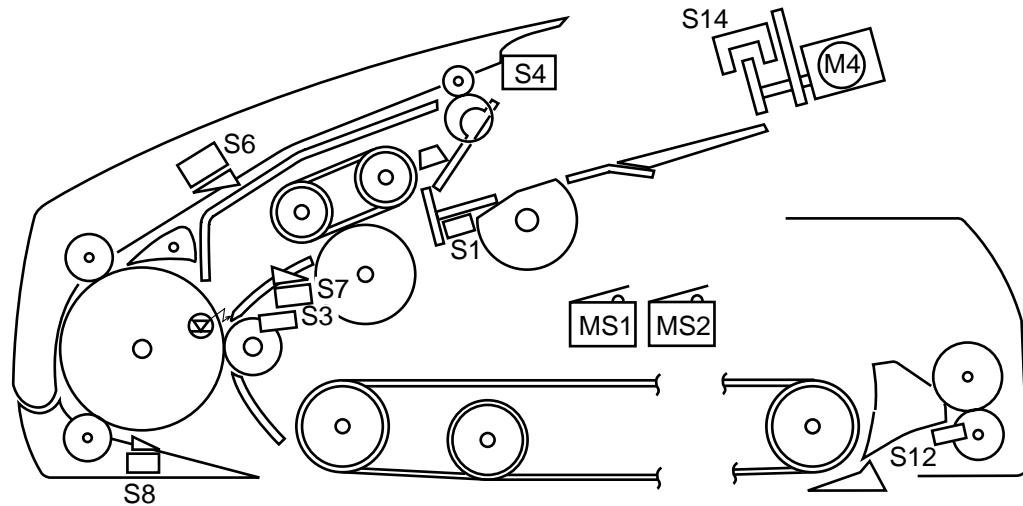

- |    |                            |    |                    |     |                       |
|----|----------------------------|----|--------------------|-----|-----------------------|
| S1 | Original tray paper sensor | S4 | Upper cover sensor | S12 | Delivery sensor 2     |
| S3 | Registration paper sensor  | S6 | Delivery sensor 1  | S14 | Re-circulation sensor |
|    |                            | S7 | Pick-up sensor     | MS1 | DADF switch           |
|    |                            | S8 | Reversal sensor    | MS2 | Upper cover switch    |

**Figure 2-234**

The timing at which the machine checks for jams is stored in memory in the microprocessor on the DADF controller PCB, and a jam is detected in terms of the presence/absence of paper at a specific sensor at the time.

When a jam is detected, the machine communicates the fact to the copier in the form of a code. (Some copiers show such codes in service mode.)

	Jam type	Sensor type	Description	Code
Pick-up	Original retraction	S1,S7	The sensor S7 does not detect the leading edge of an original 1500 msec after the pick-up motor (M1) has turned on and, in addition, the sensor S1 does not detect an original.	01H
	Pick-up delay	S7	The sensor S7 does not detect the leading edge of an original 1500 msec after the pick-up motor (M1) has turned on.	02H
	Registration delay	S3,S7	The sensor S3 does not detect the leading edge of an original 350 msec after the sensor S7 has detected the leading edge of an original.	03H

**Table 2-207a**

	Jam type	Sensor type	Description	Code
Pick-up	Double feeding	S3	The sensor S3 remains on even when the 1st original is placed on the copyboard.	06H
	Original leading edge retreat	S3	At the start of original pick-up, the sensor S3 does not detect the leading edge of an original.	08H
Reversal	Reversal delay 1	S8	At time of original reversal or delivery, the sensor S8 does not detect the leading edge of an original 140 mm or 225 msec after the belt motor (M3) has started to rotate clockwise.	11H
	Reversal stationary	S8	At time of original reversal or delivery, the sensor S8 does not detect the trailing edge of an original after a reversal delay check.	12H
	Reversal delay 2	S8	At time of original delivery pick-up, the sensor S8 does not detect the preceding original 50 mm after the belt motor has started to rotate counterclockwise. (The original to be delivered is moved back to the copyboard glass together with the original picked up).	13H
	Reversal initial paper	S8	At time of original reversal, the sensor S8 is on.	20H
	Reversal pick-up delay	S3	At time of original reversal, the sensor S3 does not detect the leading edge of the original that has been reversed 100 mm or 300 msec after the sensor S8 has detected an original.	21H
	Reversal pick-up stationary	S3	The sensor S3 does not detect the trailing edge of an original 'original size + 180 mm' after the sensor S8 has turned on.	23H
Delivery	Delivery delay	S6	At time of original delivery, the sensor S6 does not detect an original 100 mm or 250 msec after the sensor S8 has detected the leading edge of an original.	41H
	Delivery stationary	S6	The sensor S6 does not detect the trailing edge of an original 100 mm or 250 msec after a reversal stationary check.	42H
	DADF open	MS1	The DADF is opened while in operation.	81H
	Upper cover open	MS2 S4	The upper cover is opened while the DADF is in operation.	82H
	Jam original	S1	The sensor S1 does not detect the original delivered on the original tray.	83H
	Re-circulating lever idle rotation (2nd circulation or later)	S6,S3 S8,S7	At the start of original pick-up, the sensor S6, S3, or S8 (also S7 if the paper stopper plate is up) is on.	84H
	Residual original	S8	When picking up the 1st original, an original is detected on the copyboard glass.	88H
	Double feeding	S14	For the 2nd circulation or later, the re-circulating lever rotates idly without coming into contact with an original.	89H

Table 2-207b

	Jam type	Sensor type	Description	Code
Deliver	Delivery failure	S3,S6	At time of delivery in bottom separation pick-up mode, the original fails to stop (e.g., the original that has been picked up is longer than the original being delivered).	84H
	DADF open	MS1	While the copier is at reset because of, for example, the absence of paper, the DADF is opened.	91H
	Upper cover open	MS2,S4	While the copier is at reset because of, for example, the absence of paper, the upper cover is opened.	92H
	Re-circulating lever idle rotation	S13	At time of original pick-up, the re-circulating lever fell off a stack of original.	93H

Table 2-207c

**Caution:**

## 1. Result of Detection

The DADF will stop operation immediately upon detection of a jam shown in Table 2-209.

## 2. Resetting

For a pick-up delay jam, the machine may be reset by removing the original from the original tray. For other types of jams, remove the originals from the original tray, remove the jam from the DADF, and open the DADF.

**Reference:**

As a rule, detection of a condition for the first original is treated as “improperly placed original”; jams are identified starting with the detection of a condition for the second and subsequent originals.

### K. Improper Placement of Originals

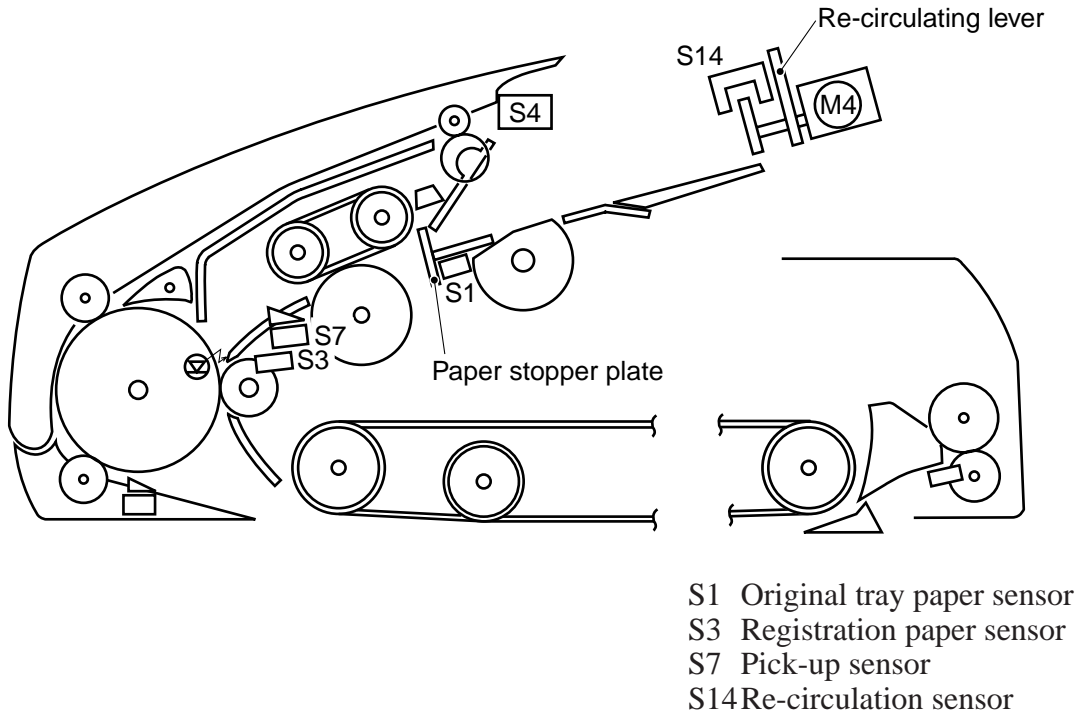

**Figure 2-235**

An improperly placed original can cause a jam or damage to the original. The machine makes a check to ensure that all originals are placed properly to prevent jams or damage. The timing of a check is stored in the microprocessor on the DADF controller, and detection is made in terms of the presence/absence of paper over a specific sensor.

When the machine detects an improperly placed original, it communicates the fact to its host copier. (Some copiers show such codes in service mode.)

Fault	Sensor	Description	DADF operation	Code
Re-circulating lever idle rotation	S11	Immediately after the re-circulation motor M4 starts to operate, the re-circulating lever rotates idly without coming into contact with an original.	Stops operation immediately upon detection.	01H
Pick-up failure	S7	The sensor S7 does not detect the leading edge of an original 1500 msec after the start of pick-up.	The separation belt, feeding roller, and pick-up roller stop operation immediately. The original moving in advance is delivered after the end of copying; then, the DADF stops operation.	03H
Paper stopper plate overriding	S7	At time of placement of originals, the originals ride over the paper stopper plate.	Stops operation immediately upon detection.	05H
Count mismatch	S3	The number of originals placed on the original tray after jam removal is as follows; see Note:  <div style="border: 1px solid black; padding: 5px; display: inline-block;">                     Original copied &gt; Original placed on tray                 </div>	Stops operation immediately upon detection.	11H
Original count	S3	The re-circulating lever does not fall under the original tray, not enabling detection of the last original.  <div style="border: 1px solid black; padding: 5px; display: inline-block;">                     Reference                      Normally, the original tray can hold as many as 50 sheets of A5, STMT, A4, B5, or LTR or 25 sheets of A3, B4, 279x432mm (11"x17"), or LGL.                 </div>	Stops operation after counting 100 sheets.	12H
Original extraction	S14	The re-circulating lever fell under the original tray while an original is being processed.	Stops operation immediately upon detection.	13H
Wrong original size	S3	The size of the original that is picked up is of a non-default size.	Stops operation immediately upon detection.	14H
Wrong original size or size mix in reduced page composition mode	S3	1. The original that is picked up is of a type not supported by reduced page composition mode. 2. The original that is picked up is of a size different from the size of the first original.	Stops detection immediately upon detection.	15H

Table 2-208

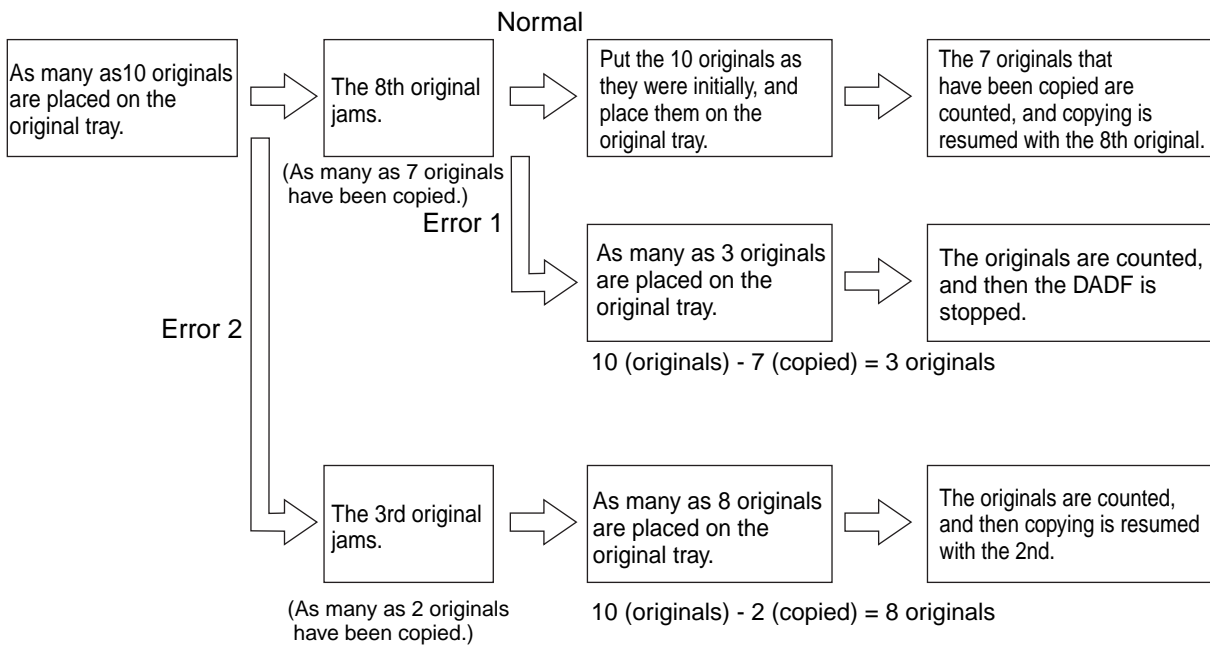

When a jam occurs, the host copier remembers how many originals have been copied. The count is sent to the DADF after jam removal, and the DADF circulates the originals that have been copied; it then places originals that have not been copied on the copyboard for copying. This is why normal copying would not be possible if a different number of originals are placed on the original tray after jam removal.

In the above chart, error 1 will be treated as a condition in which a different number of originals are placed after jam removal; in such a case, both the DADF and the copier stop operation to indicate an error. The operation continues, however, for error 2.

**1. Resetting**

To reset, remove all originals from the original tray, and then place the originals once again. Some copiers indicate an appropriate message. Be sure to follow such a message when placing the originals.

In reduced page composition mode, on the other hand, remove the originals from the original tray, and open the DADF once.

### III. POWER SUPPLY

#### A. Outline

Figure 2-301 is an outline diagram of the machine's power supply system.

The machine's power supply is provided by its host copier with 24 V (24 VP, 24 VL).

24 VP is mainly used for loads, and is cut off when the machine is opened or its upper cover is opened. The circuit breaker (CB1) operates to cut off the power to protect the circuit in response to overcurrent.

24 VL is converted by the regulator into 5 V, and is used by the logic system and sensors.

The fuse resistance (R26) melts in response to overcurrent in the circuit, thereby cutting off the power and protecting the circuit.

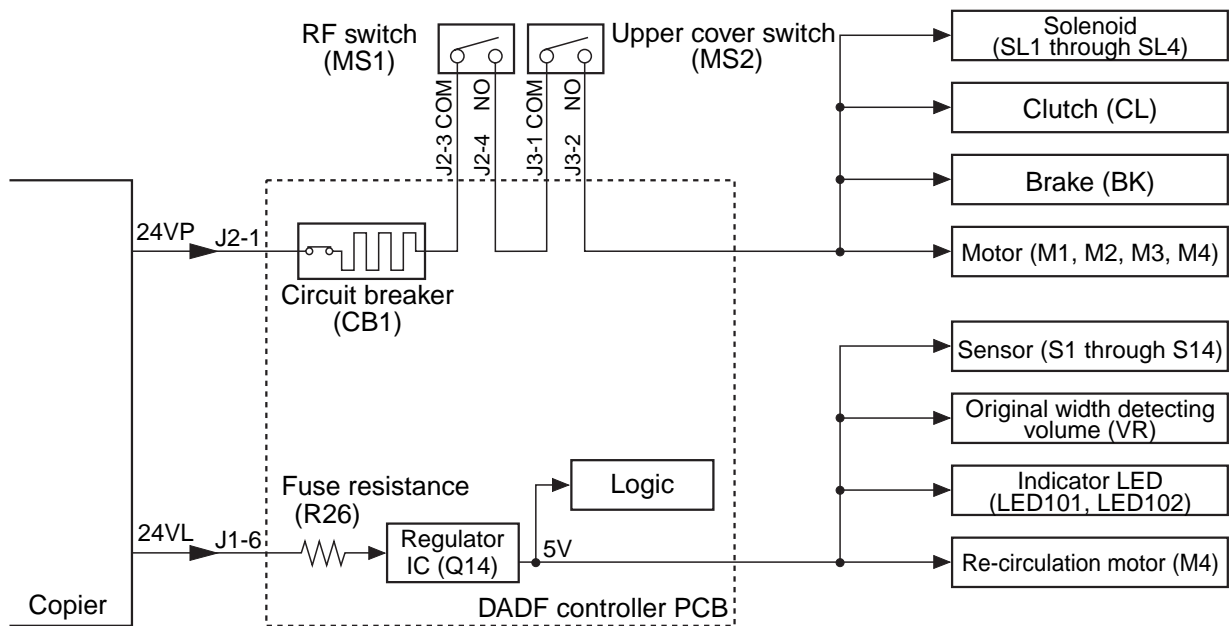

Figure 2-301





---

# CHAPTER 3

---

## MECHANICAL SYSTEM

---

I. BASIC CONSTRUCTION .....	3-1	G. Delivery Roller Unit	
A. External Covers .....	3-1	(top pick-up mode) .....	3-21
B. Switches .....	3-3	H. Reversing Guide .....	3-22
C. Adjusting the DADF Height .....	3-5	I. Stopper Plate Solenoid .....	3-24
II. DRIVE SYSTEM .....	3-6	J. Positioning the Paper Retaining	
A. Removing the Pick-Up		Plate Solenoid (SL2) .....	3-25
Motor Unit .....	3-6	K. Positioning the Paper Deflecting	
B. Removing the Feeder		Solenoid (SL3) .....	3-26
Motor Unit .....	3-6	L. Stamp Solenoid .....	3-26
C. Belt Motor .....	3-7	M. Feeding Belt .....	3-28
D. Removing the Clutch Unit .....	3-9	IV. CLEANING .....	3-31
E. Delivery Motor .....	3-10	A. Belt Assembly .....	3-31
III. FEEDING SYSTEM .....	3-11	B. Sensors .....	3-31
A. Pick-Up Roller .....	3-11	C. Separation Guide .....	3-34
B. Removing the Separation		V. FEEDING .....	3-35
Belt Unit .....	3-12	A. Pick-Up Drive Assembly .....	3-35
C. Feeding Roller Unit .....	3-12	B. Right Delivery Drive	
D. Registration Roller .....	3-14	Assembly .....	3-35
E. Delivery/Reversing Roller .....	3-16		
F. Delivery Roller Unit			
(bottom pick-up mode) .....	3-20		



## I. BASIC CONSTRUCTION

### A. External Covers

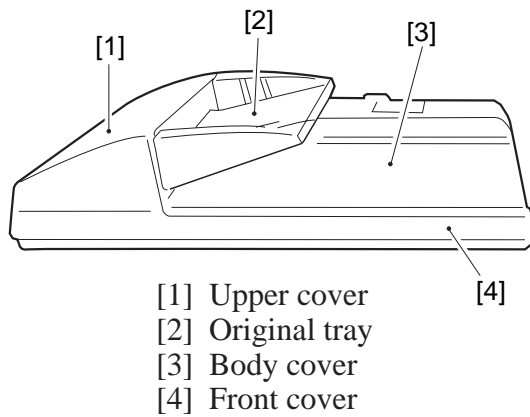
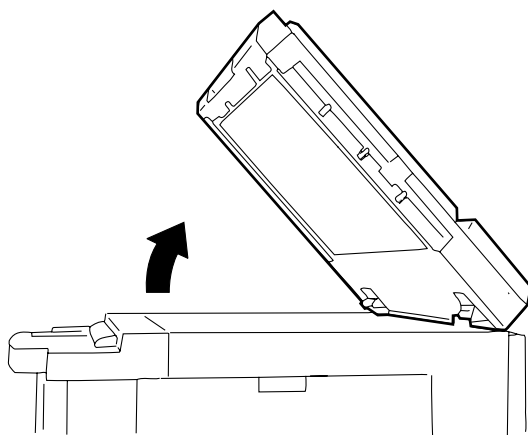

**Figure 3-101**

Remove the covers as shown when cleaning, inspecting, and repairing the inside of the machine.

#### 1. Removing the DADF

- 1) Turn on off the copier.
- 2) Disconnect the communication cable of the DADF from the copier.
- 3) Open the DADF fully.



**Figure 3-102**

- 4) Go to the rear of the copier, and lift the DADF upright to remove.

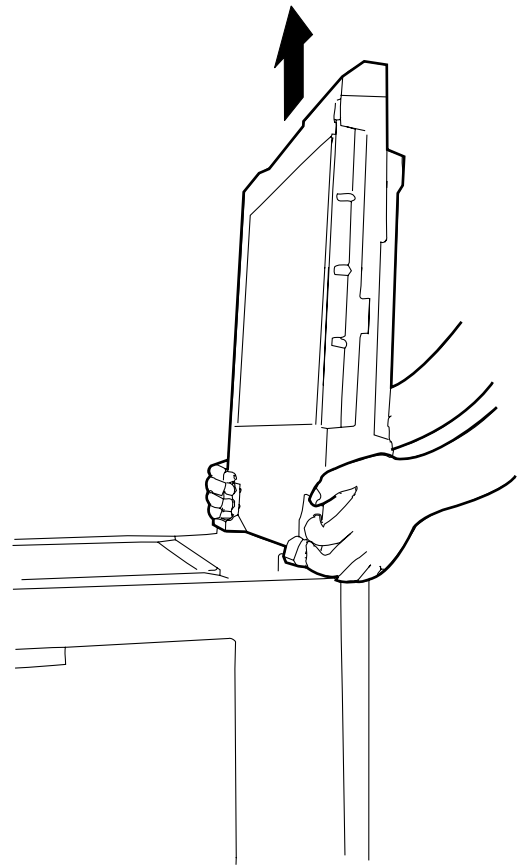

**Figure 3-103**

#### Reference:

The feet of the hinges of the machine are equipped with a locking mechanism designed to prevent slippage. When detaching the machine from the copier, you must fully open it to disengage its locks.

When removing the DADF from the copier, be sure to hold it as shown in **Figure 1-103**, not supporting it by the delivery assembly to prevent faulty delivery.

**2. Removing the Body Cover**

- 1) Remove the seven mounting screws [1], and detach the body cover.

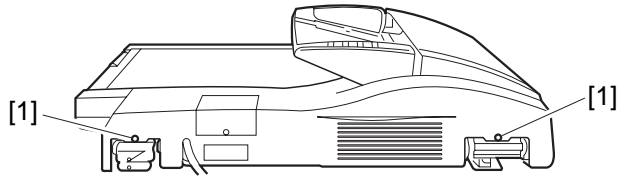

**Figure 3-104**

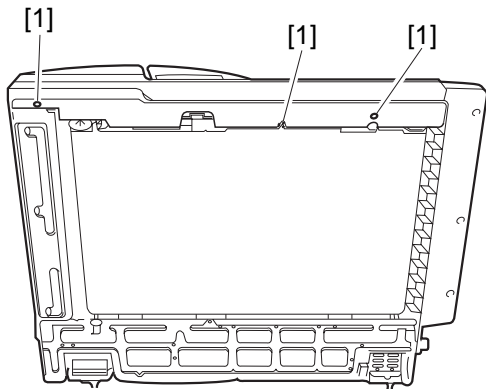

**Figure 3-105**

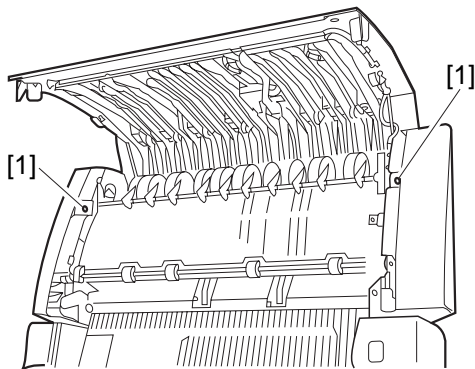
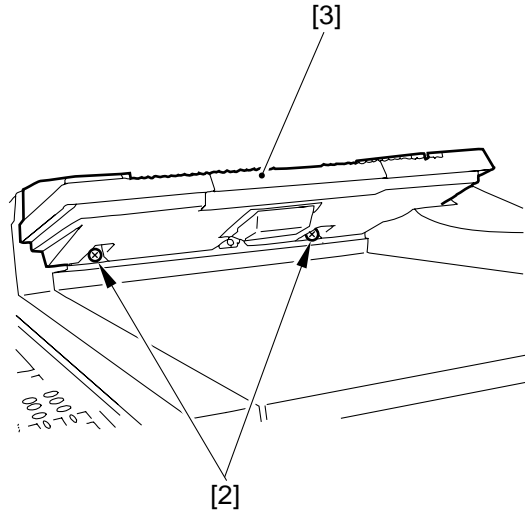

**Figure 3-106**

- 2) Remove the two mounting screws [2], and detach the original tray.

**Caution:**

The original tray is connected by means of a cable. Take extra care not to damage the cable during work.



**Figure 3-107**

- 3) While avoiding the original tray, detach the body cover and the front cover.

### 3. Side Guide Lock

The side guide of the machine is equipped with a side guide lock so that it will not open farther than 297 mm (A/A3).

If an original longer in width than 297 mm is used, the side guide lock must be removed (300 mm max.).

- 1) Loosen the screw [1], and remove the side guide lock [2].

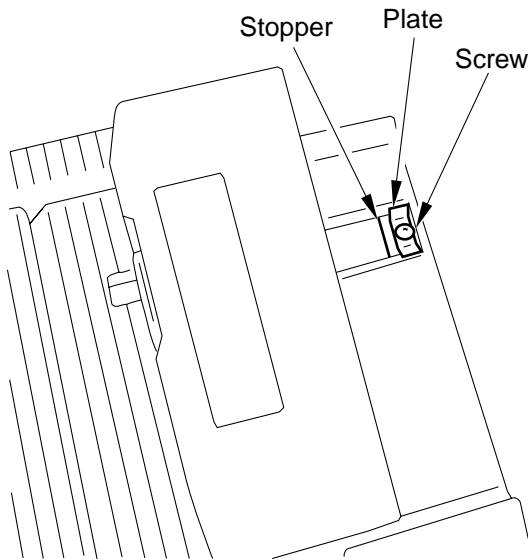

Figure 3-108

**Caution:**

When making copies, be sure to adjust the side guide to the size of the original. If the side guide is improperly positioned, the original will tend to move askew.

### B. Switches

The machine is equipped with two microswitches (DADF switch MS1 and upper cover open/closed switch MS2) so that the machine will not operate when it or its upper cover is open.

#### 1. Adjusting the DADF Switch (MS1)

- 1) Remove the body cover.
- 2) Open and close the DADF, and adjust the retaining plate [2] so that the DADF switch (MS1) [1] turns on and off while the distance from the copyboard glass to the DADF end is between 10 and 100 mm.

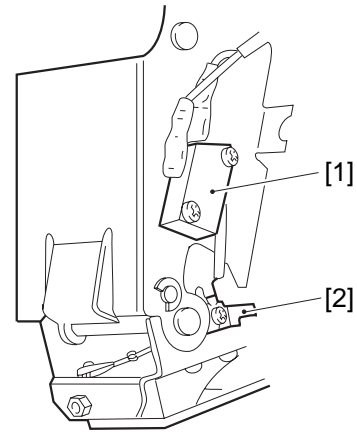

Figure 3-109

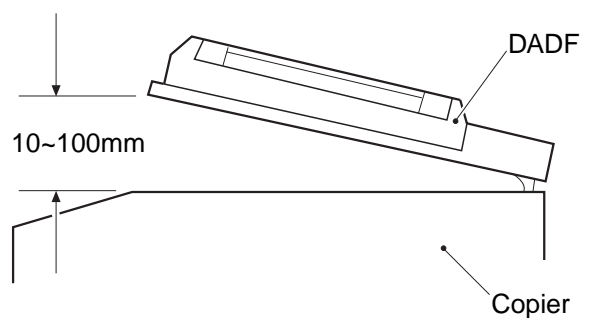

Figure 3-110

**2. Upper Cover Switch (MS2)**

- 1) Check to make sure that both upper cover switches (front, rear) are on when the upper cover is closed.

**3. Mounting the Original Width Detecting Volume**

- 1) Loosen the two screws [2], and detach the side guide [1].

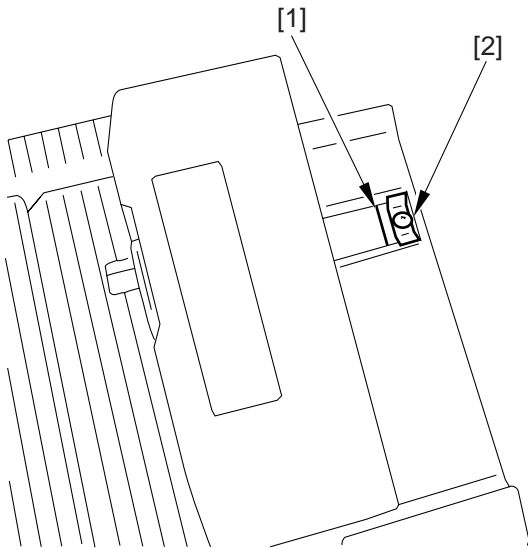

**Figure 3-111**

- 2) Open the side guide at the rear [3] and the front [4] fully.

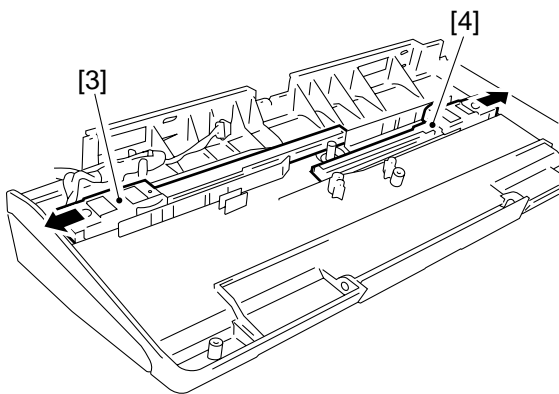

**Figure 3-112**

- 3) Mount the gear [5].

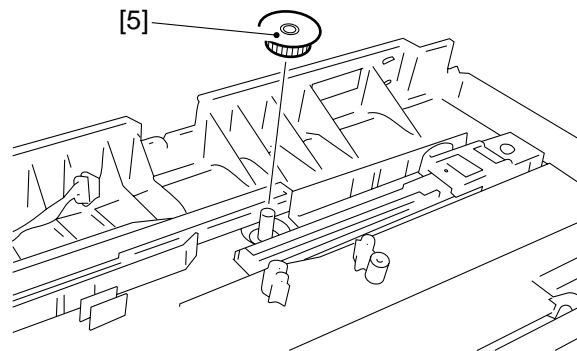

**Figure 3-113**

- 4) Turn the original width detecting volume [6] fully in the direction of the arrow; then, turn it in the opposite direction (equivalent of half a tooth) so that it is as indicated in the figure.

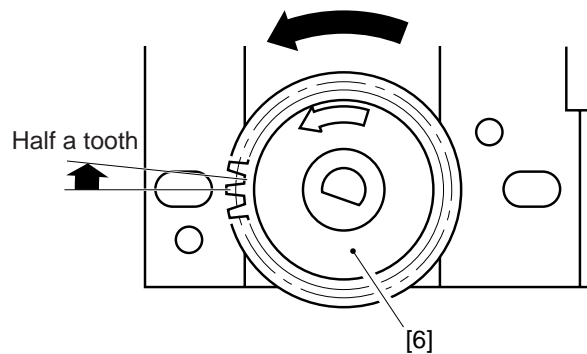

**Figure 3-114**

- 5) Keeping the original width detecting volume [6] as in step 4), mount it to the original tray [7], and fix it in position with screws [8]; then, connect the connector [9].

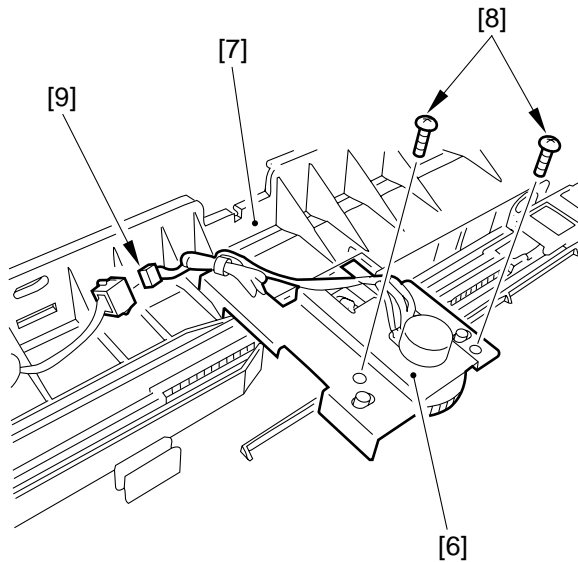
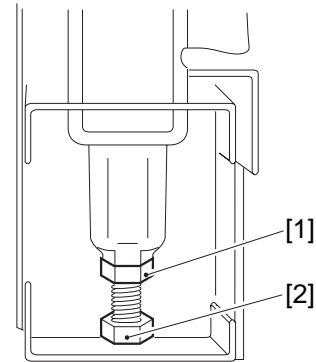

**Figure 3-115**

- 6) Mount the side guide lock removed in step 1, and execute adjustments of the original width detecting volume. (For adjustments, see p. 5-18.)

### C. Adjusting the DADF Height

- 1) Remove the copier's rear side plate. Loosen the locking nut [1], and turn the height adjusting screw [2] so that the left/right rear foot is  $0.2 \pm 0.1$  mm from the horizontal size plate of the copyboard glass.



**Figure 3-116**

- 2) After making adjustments, check to make sure that the left and right front rubber feet are in contact with the copyboard glass.

## II. DRIVE SYSTEM

### A. Removing the Pick-Up Motor Unit

- 1) Remove the body cover.
- 2) Remove the tie-wrap as necessary.
- 3) Disconnect the connector J12 [2] from the DADF controller PCB [1].

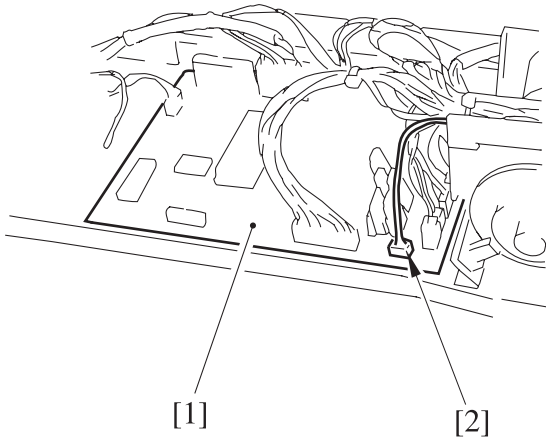

Figure 3-201

- 4) Remove the screw [3], and remove the cable guide [4].

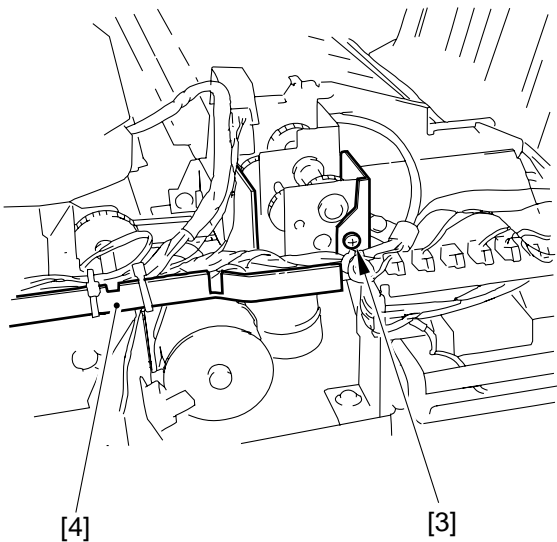

Figure 3-202

- 5) Disconnect the connector [5] of the upper cover sensor S4.
- 6) Remove the two mounting screws [6], and detach the pick-up motor unit [7].

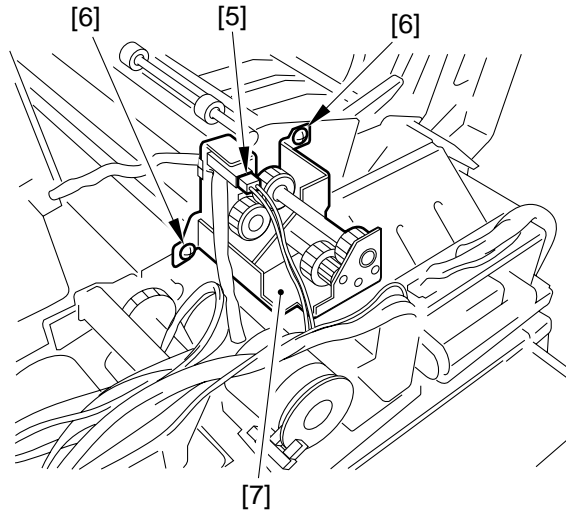

Figure 3-203

### B. Removing the Feeder Motor Unit

- 1) Remove the pick-up motor unit.
- 2) Remove the tie-wrap as necessary.
- 3) Disconnect the connector J11 [2] from the DADF controller PCB [1].

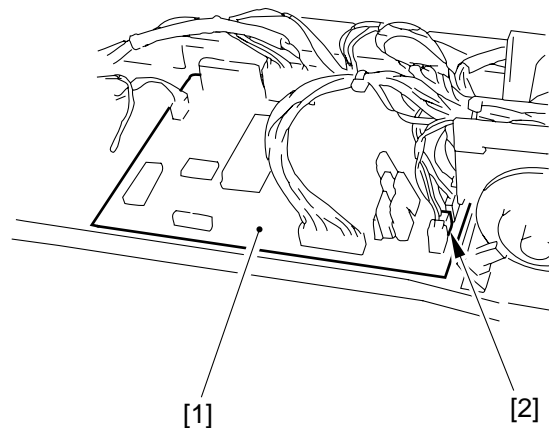

Figure 3-204



- 4) Remove the two screws [4], and disconnect the connector [3] of the feeder motor clock sensor S9.

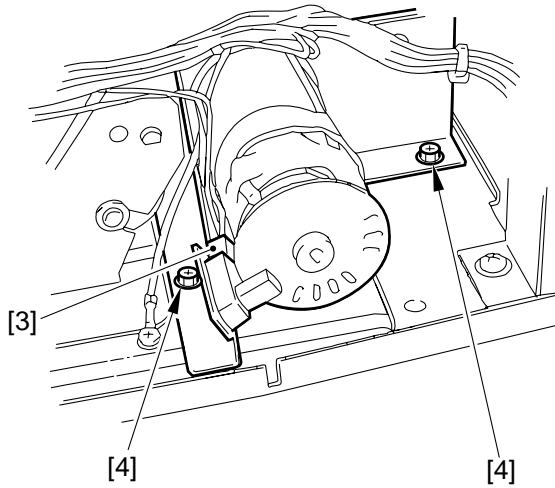

Figure 3-205

- 5) Detach the two drive belts [5], and detach the feeder motor unit [6].

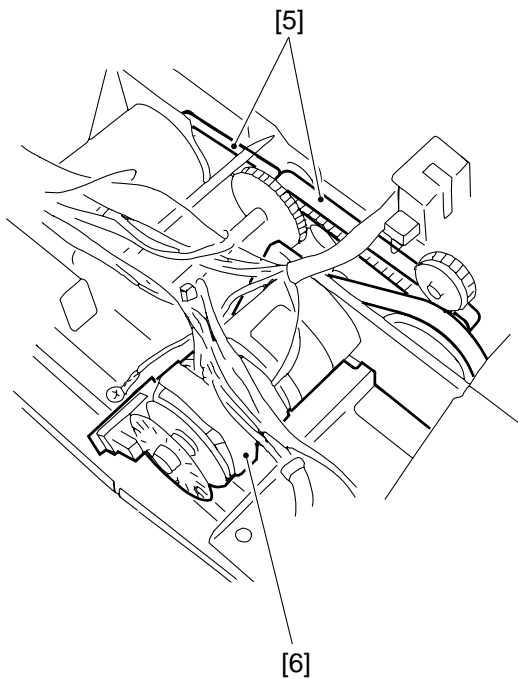

Figure 3-206

## C. Belt Motor

### 1. Removing the Belt Motor

- 1) Remove the DADF from the copier.
- 2) Remove the feeder motor unit.
- 3) Remove the tie-wrap as necessary.
- 4) Disconnect the connectors J6 [1], J7 [3], and J13 [3] of the DADF controller PCB.

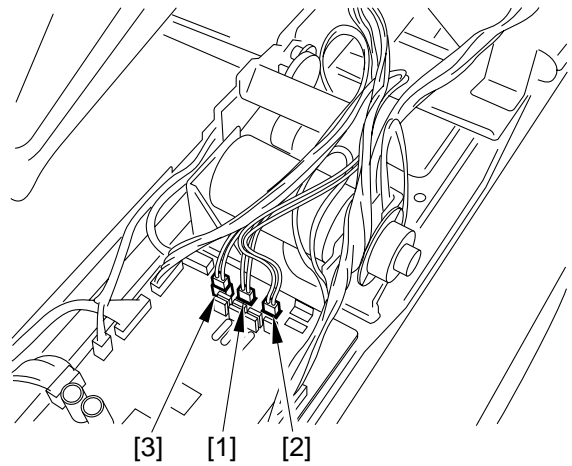

Figure 3-207

- 5) Disconnect the connector [4] of the belt motor clock sensor (S10).

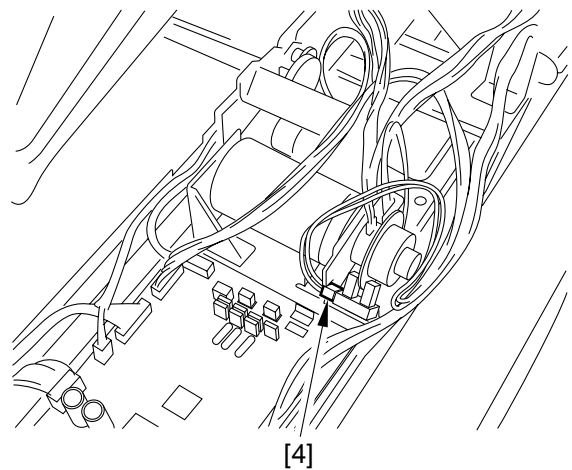

Figure 3-208

- 6) Mark the position of the belt motor count [5] on the DADF with a scribe, and remove the three screws [6].

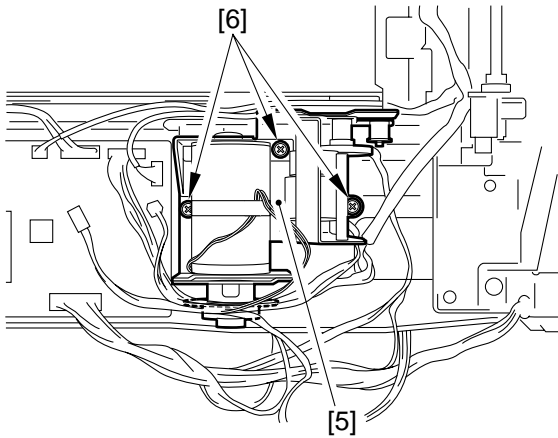

Figure 3-209

- 7) Detach the feeding belt drive roller side [8] of the timing belt [7], and detach the belt motor unit [5].

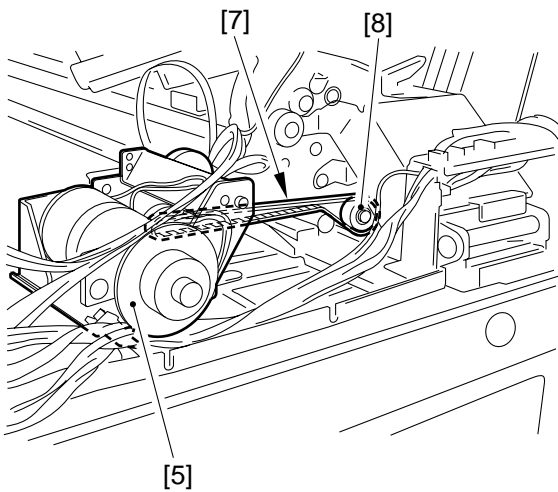
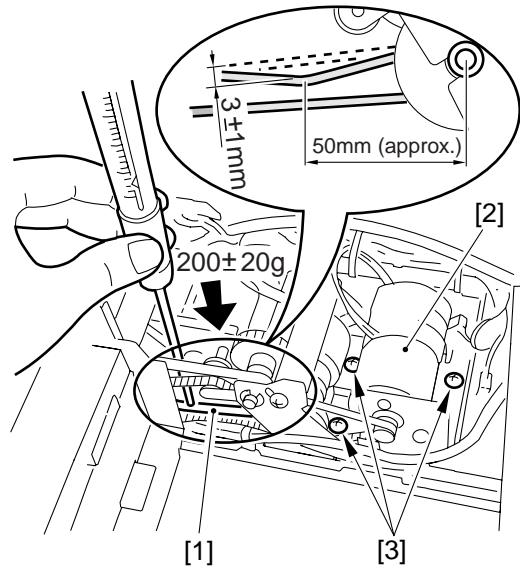

Figure 3-210

## 2. Making Adjustments

- 1) Secure the belt motor unit [2] in place with three screws so that the displacement is  $3 \pm 1$  mm when the timing belt is pushed under a force of  $3 \pm 1$  mm.



The spring gauge must be capable of measuring 600 g or so (CK-0058).

Figure 3-211

- 2) Pull the belt tensioner [4] with a force of  $500 \pm 50$  g, and secure it in place with the screw [5].

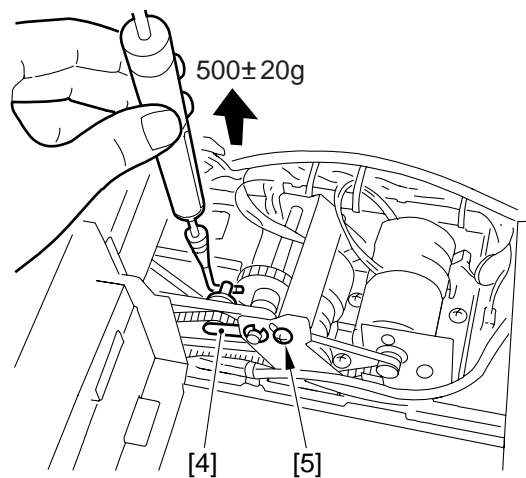

The spring must be capable of measuring 600 g or so (CK-0058).

Figure 3-212

## D. Removing the Clutch Unit

- 1) Remove the belt unit [1].
- 2) Detach the drive belt [2].

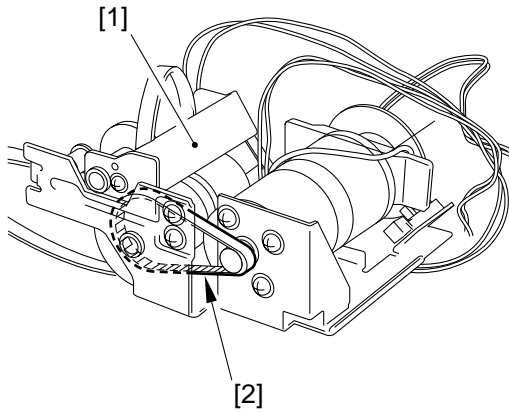

**Figure 3-213**

- 3) Remove the E-ring [3].
- 4) Displace the bush [4], and remove the clutch unit [5].

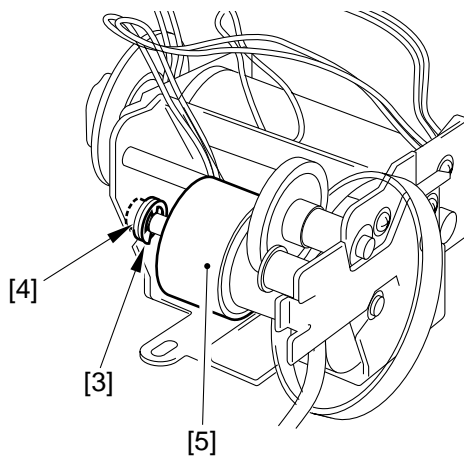

**Figure 3-214**

### Caution:

When mounting the clutch unit, be sure that the slip stop [6] of the clutch engages with the stopper [7] of the mount.

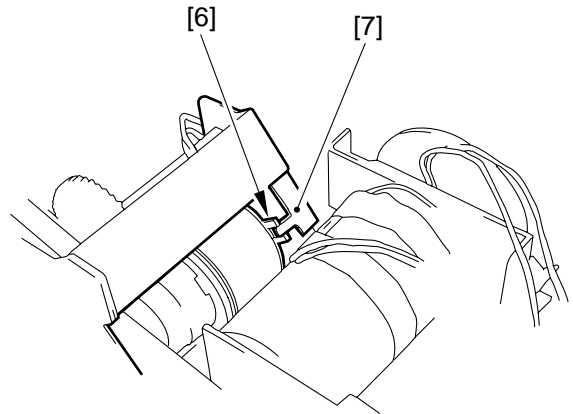

**figure 3-215**

## E. Delivery Motor

- 1) Remove the body cover.
- 2) Disconnect the three connectors [1].

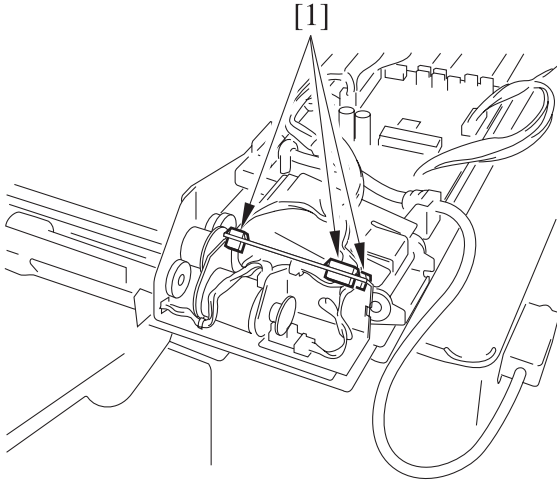

Figure 3-216

- 3) Remove the two screws [2], and free the cable [4] from the cable retainer [3]; then, detach the delivery monitor unit [5].

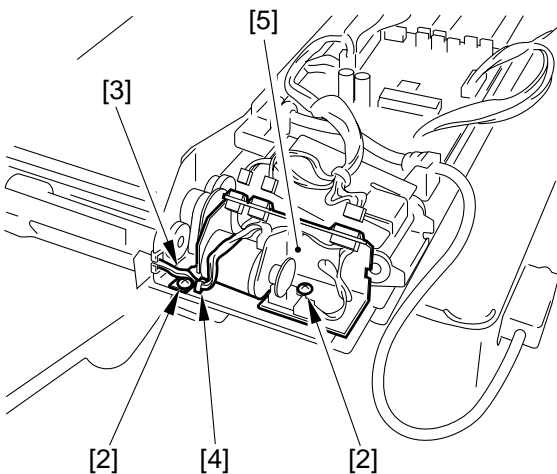

Figure 3-217

- 4) Disconnect the connector [6], and remove the two screws [7]; then, detach the delivery motor [8].

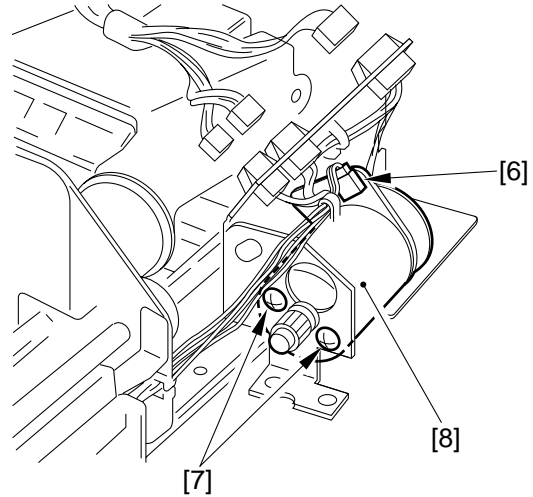

Figure 3-218

### III. FEEDING SYSTEM

#### A. Pick-Up Roller

- 1) Remove the body cover.
- 2) Remove the two screws [1], and detach the original tray mount [2].

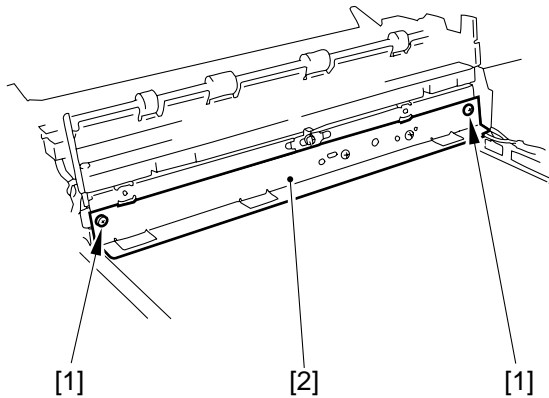

Figure 3-301

- 3) Remove the screw [3], and detach the paper retaining solenoid [4].

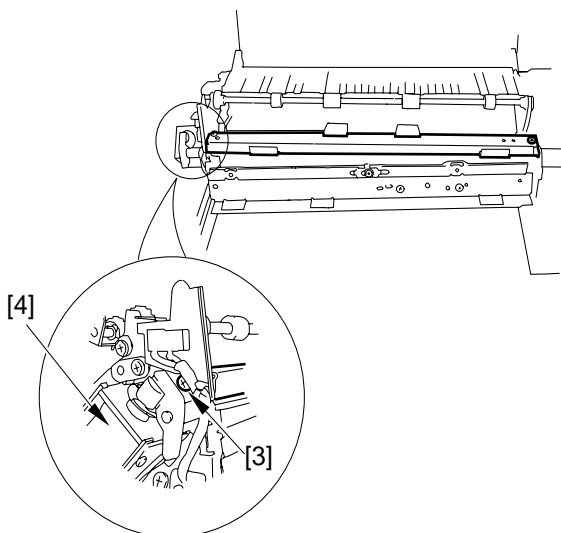

Figure 3-302

- 4) Remove the two screws [5], and detach the original inlet guide plate [6].

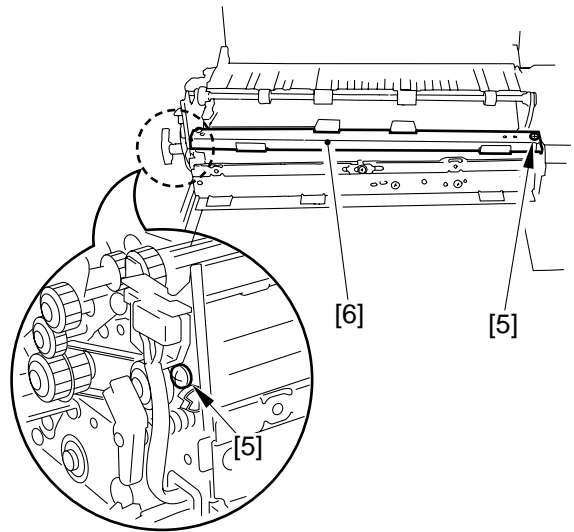

Figure 3-303

- 5) Rotate the pick-up roller [7] so that it is as shown in the figure; then, remove the screw [8], and detach the pick-up roller.

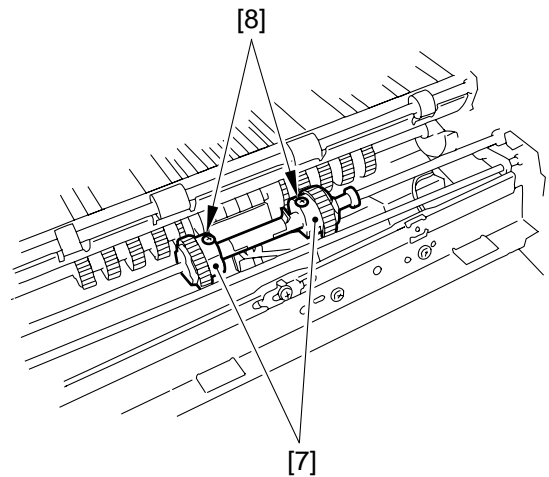

Figure 3-304

## B. Removing the Separation Belt Unit

- 1) Remove the body cover.
- 2) Detach the reversing roller drive belt [1].

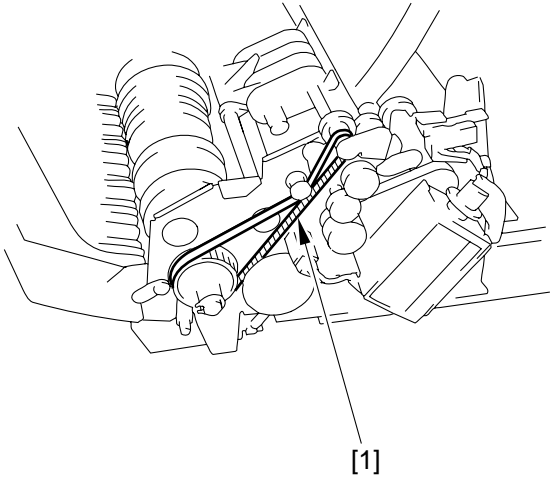

Figure 3-305

- 3) Remove the two screws [2], and detach the separation belt unit [3] together with the fixing plate [4].

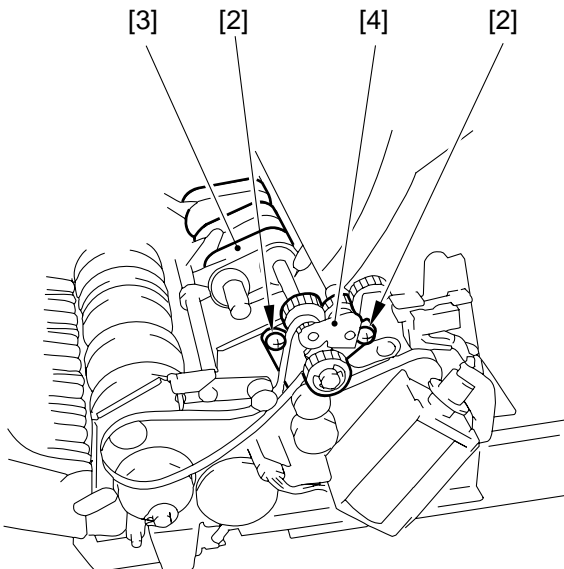

Figure 3-306

## C. Feeding Roller Unit

- 1) Remove the body cover.
- 2) Remove the original tray mount.
- 3) Remove the original inlet guide plate.
- 4) Remove the separation belt unit.
- 5) Remove the four screws [5], and detach the separation guide plate [6].

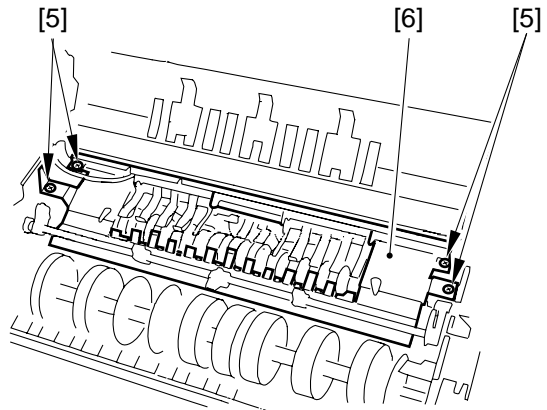

Figure 3-307

- 6) Remove the two screws [8], and detach the inside guide plate [7].

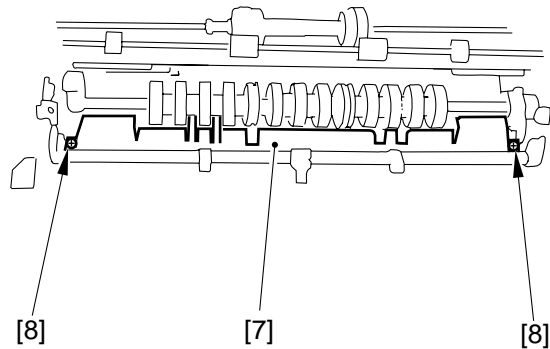

Figure 3-308

- 7) Remove the screw [9], and detach the stopper [10].

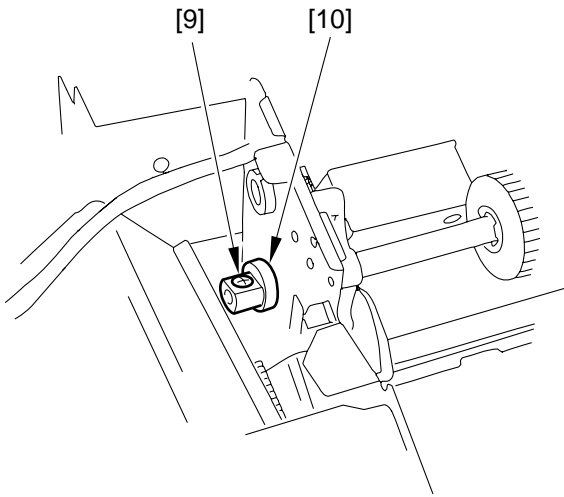

Figure 3-309

- 10) Remove the E-ring [16], and shift the arm [17] and the gear [18] in the direction of the arrow.

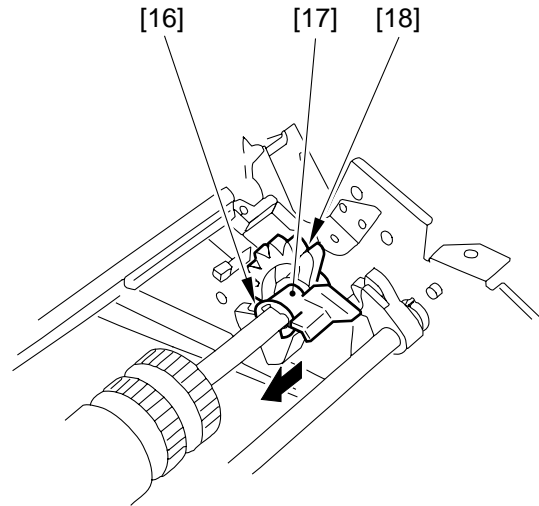

Figure 3-311

- 8) Remove the E-ring [11], and detach the idler gear [12].  
 9) Remove the E-ring [13], and detach the gear [14] and the timing belt [15]. (Take care not to drop the pin.)

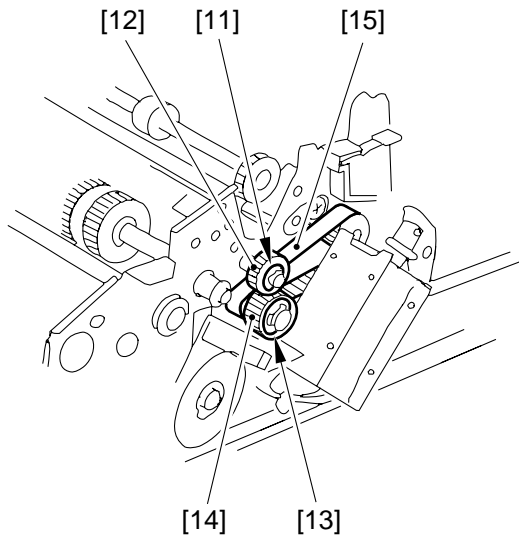

Figure 3-310

- 11) Remove the E-ring [19], and shift the bush [20] in the direction of the arrow; then, remove the feeding roller unit [21].

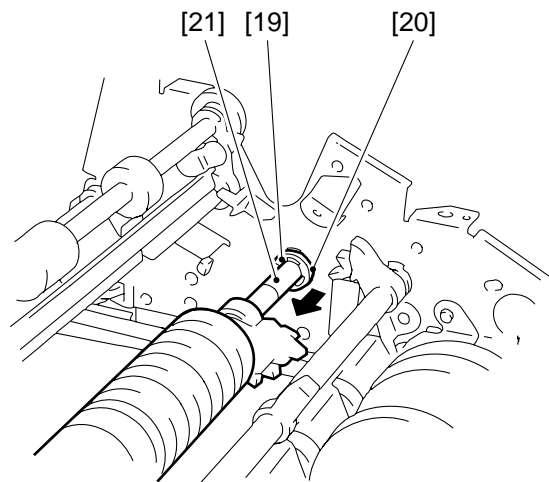

Figure 3-312

## D. Registration Roller

- 1) Remove the DADF from the copier.
- 2) Remove the body cover.
- 3) Remove the feeding roller unit.
- 4) Remove the pick-up motor unit.
- 5) Remove the four screws [2], and detach the right hinge unit [1].

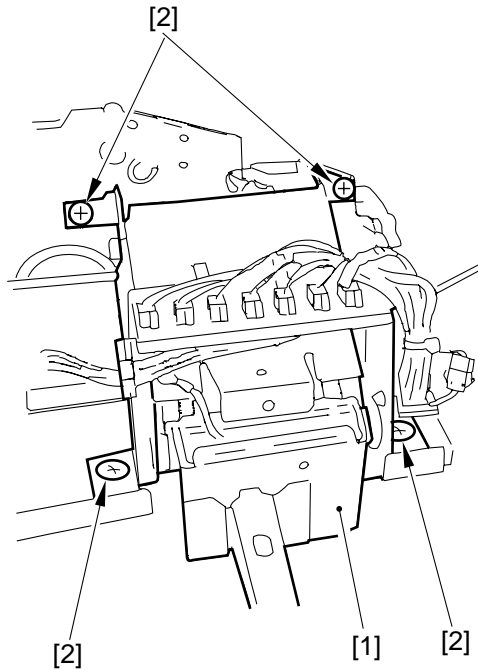

Figure 3-313

- 6) Remove the E-ring [3], and detach the bush [4].

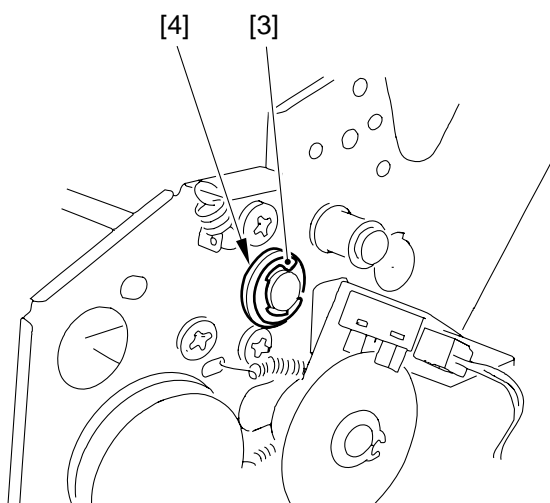

Figure 3-314

- 7) Remove the screw [5], and detach the solenoid mount [6].

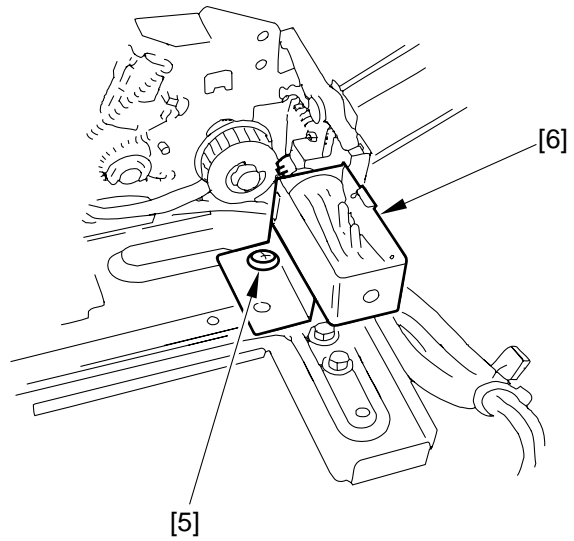

Figure 3-315

- 8) Remove the spring [7] and the screw [8]; then, detach the arm [9].

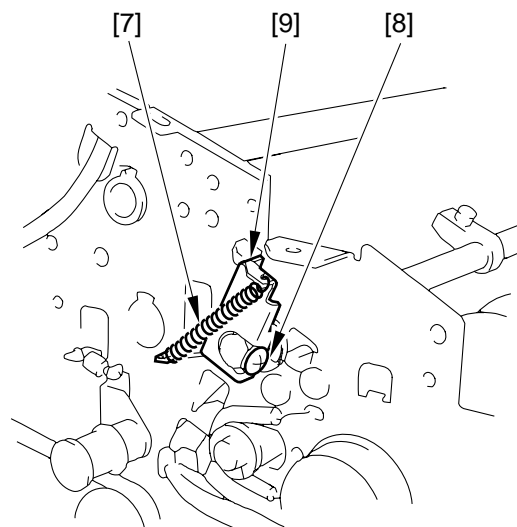

Figure 3-316



- 9) Remove the E-ring [10] and the bush [11]; then, detach the link arm shaft [12].

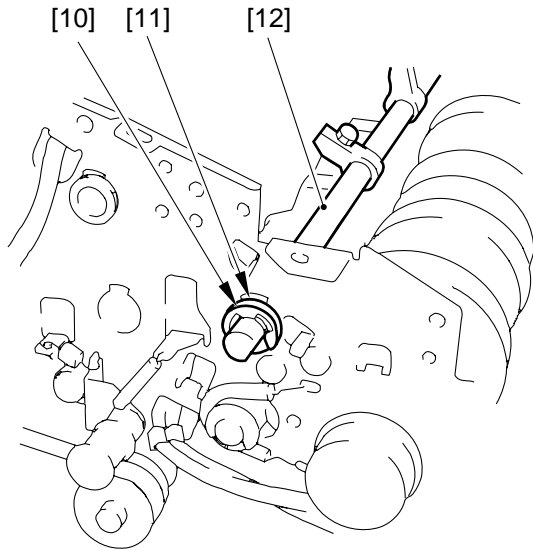

Figure 3-317

- 10) Remove the two screws [13], and remove the sensor mount [14].

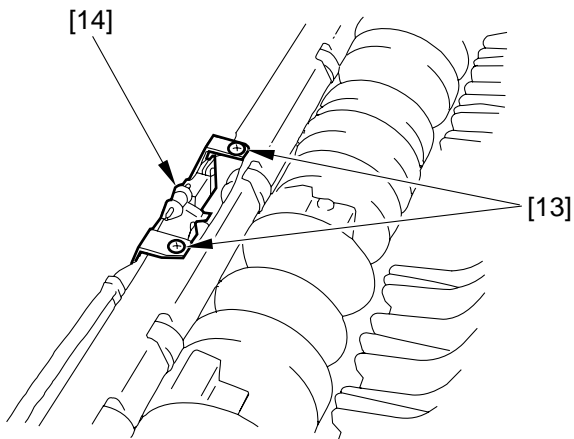

Figure 3-318

- 11) Remove the E-ring [15], tension spring [16], bush [17], and two screws [18].

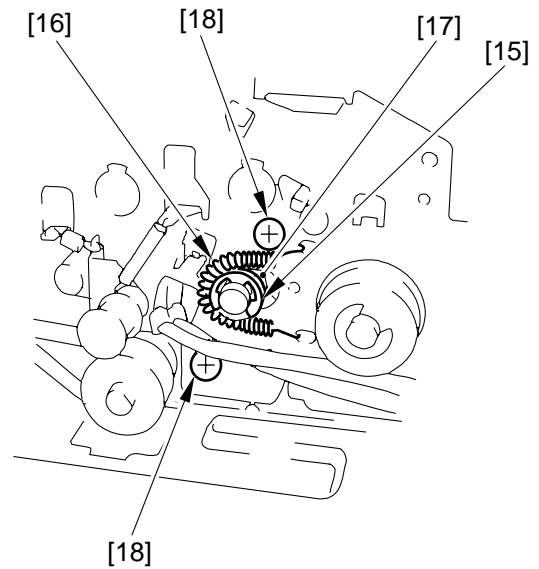

Figure 3-319

- 12) Remove the grip ring [19], clock plate [20], sensor mount [21], and spring [22].

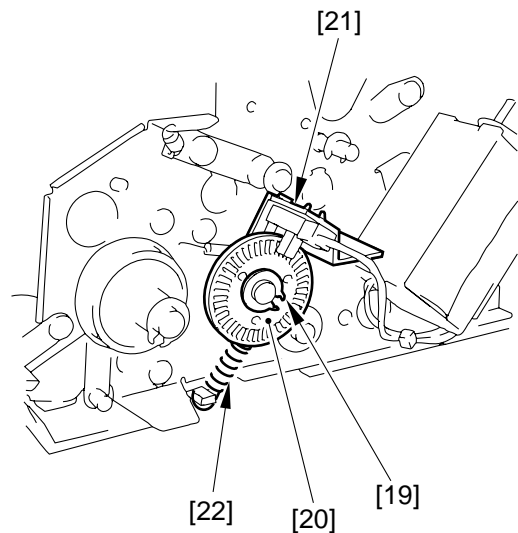

Figure 3-320

- 13) Remove the grip ring [23], tension spring [24], bush [25], and two screws [26]; then, detach the registration roller [27].

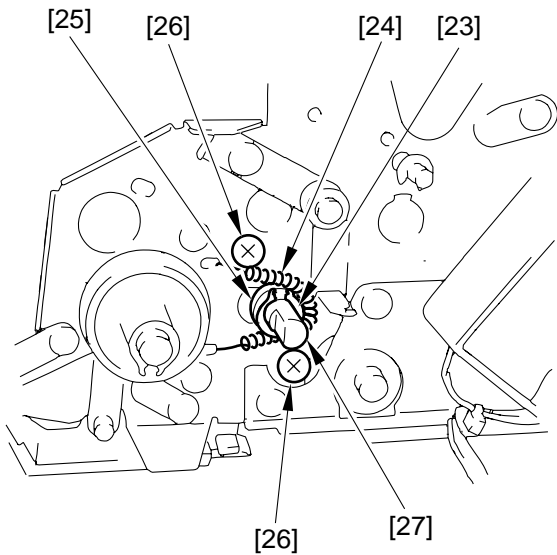

Figure 3-321

## E. Delivery/Reversing Roller

- 1) Remove the DADF from the copier.
- 2) Remove the body cover.
- 3) Remove the registration roller.
- 4) Remove the two E-rings [1], gear [2], timing belt [3], and bush [4]. (Take care not to drop the pin.)

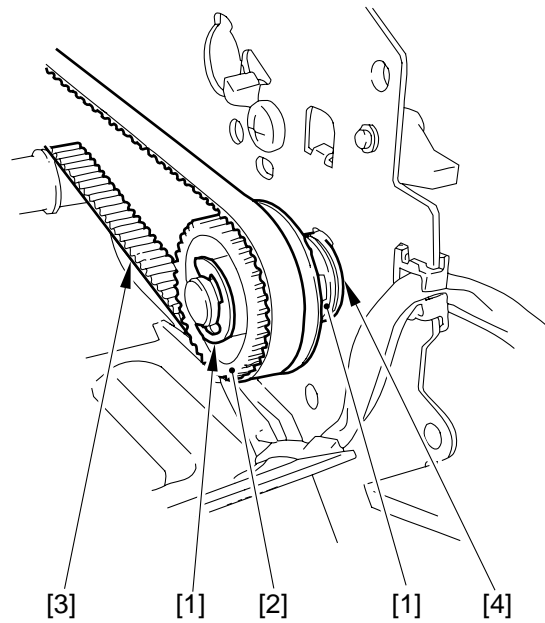

Figure 3-322

- 5) Remove the gear [5]. (Take care not to drop the pin.)

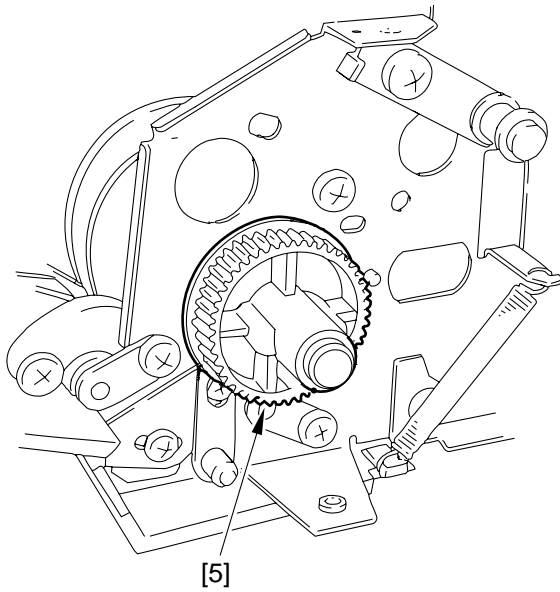

Figure 3-323

- 6) Remove the grip ring [6], and remove the bush [7].

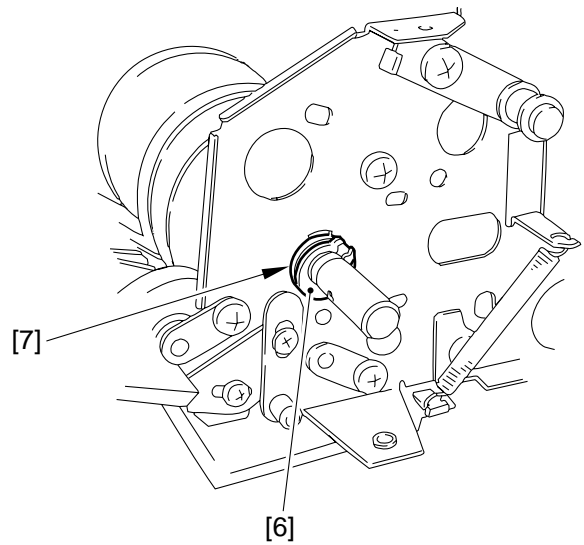

Figure 3-324

**Reference:**   
Remove the gear while unlocking it.

- 7) Remove the spring [8] and the screw [9]; then, detach the lower guide stopper [10].

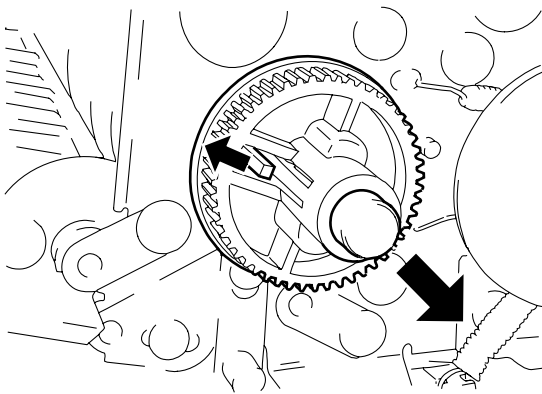

Figure 3-323-a

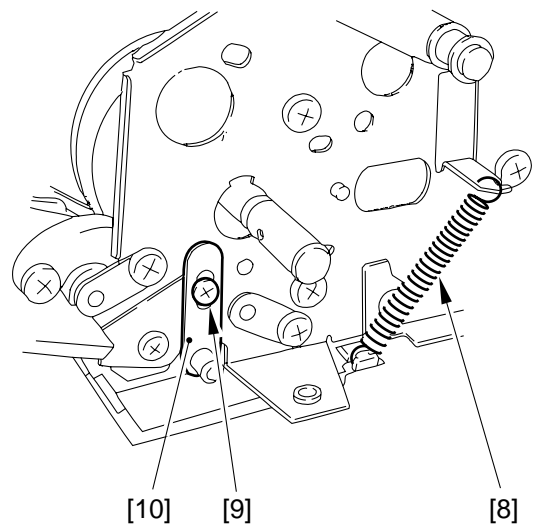

Figure 3-325

8) Remove the spring [11].

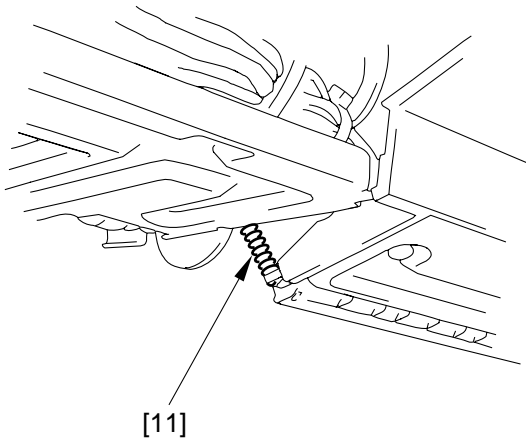

Figure 3-326

9) Remove the screw [13], and detach the sensor cover [12]; then, disconnect the sensor connector [14], and remove the registration sensor [15] by lifting it.

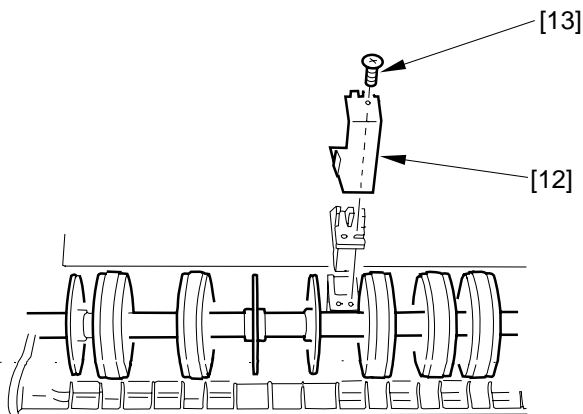

Figure 3-327

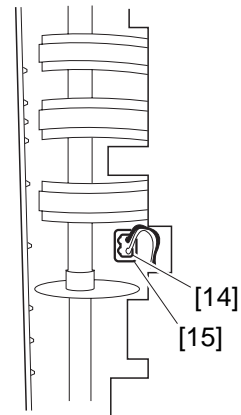

Figure 3-328

10) Remove the paper guide [16].

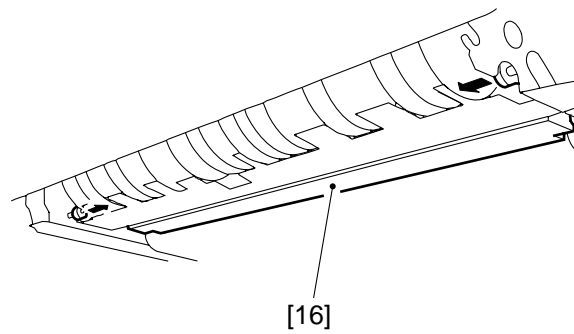

Figure 3-329

- 11) Remove the two screws [17] at the front and the two screws [18] at the rear; then, detach the reversing plate [19] to the bottom.

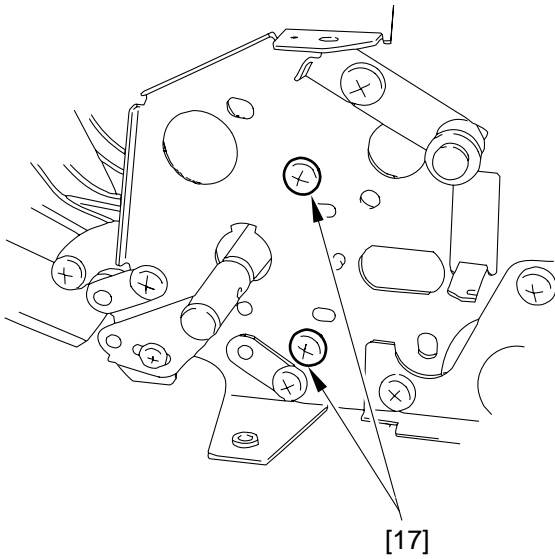

Figure 3-330 (front)

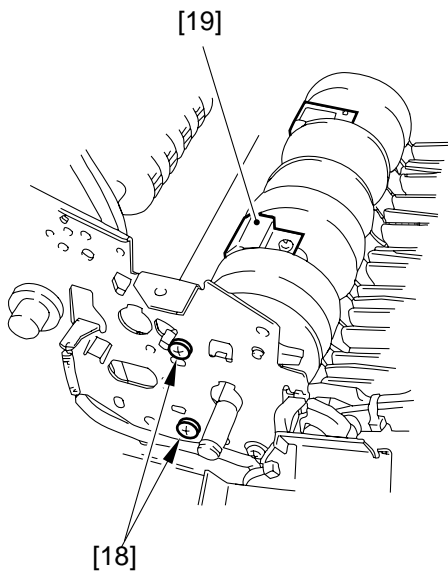

Figure 3-331 (rear)

- 12) Remove the four screws [20], and remove the front plate [21].

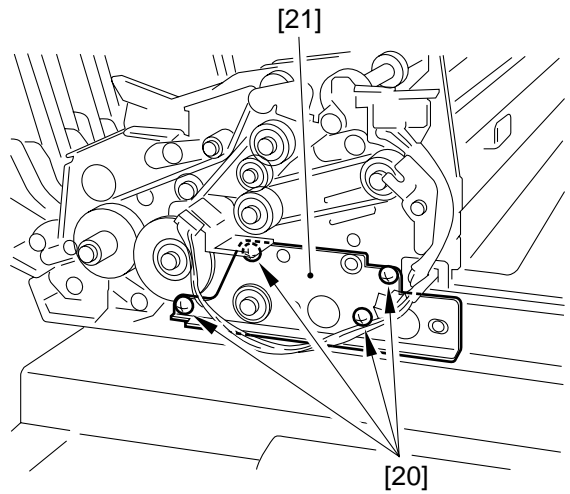

Figure 3-332

- 13) Remove the delivery/reversing roller [22].

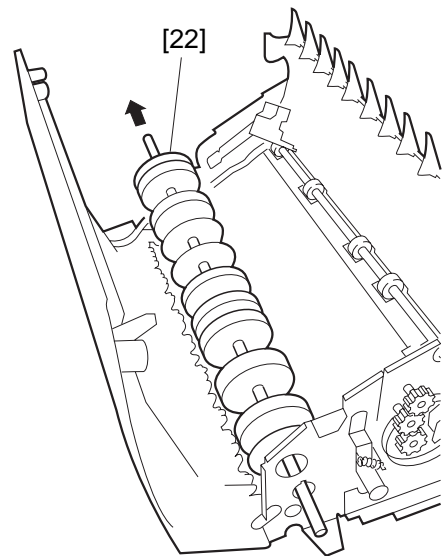

Figure 3-333

## F. Delivery Roller Unit (bottom pick-up mode)

- 1) Remove the body cover.
- 2) Remove the pick-up motor .
- 3) Remove the screw [1].

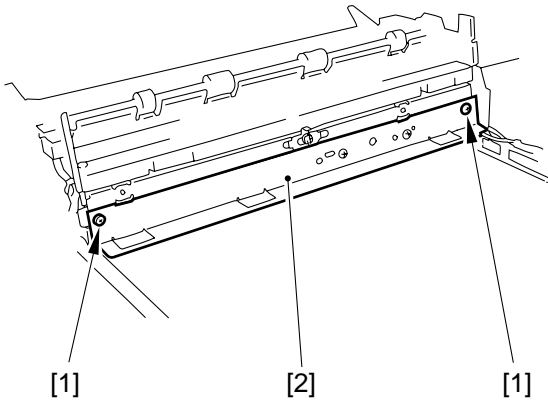

Figure 3-334

- 4) Remove the E-ring [2].

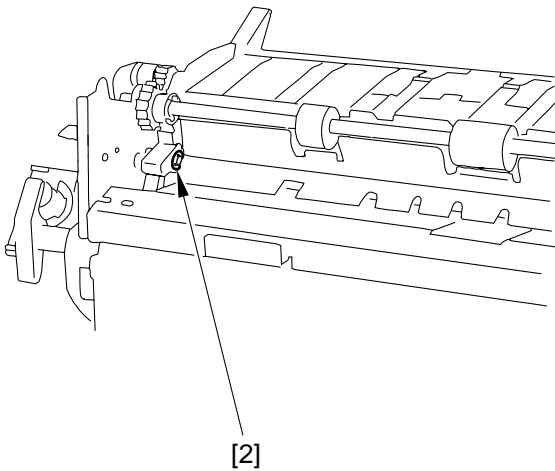

Figure 3-335

- 5) Remove the screw [3], and remove the fixing pin [4]; then, detach the delivery roller unit [5].

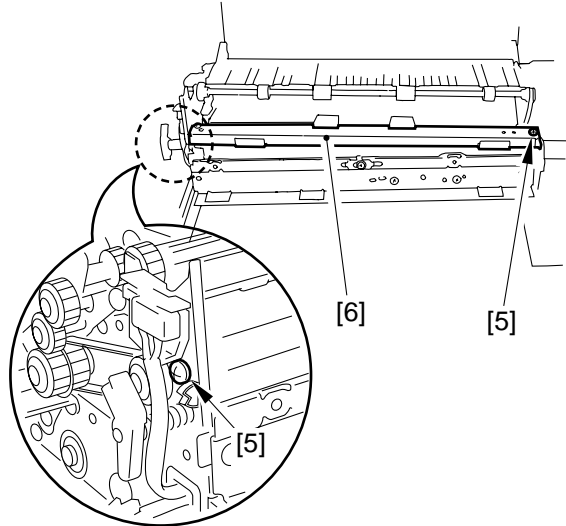

Figure 3-336

### G. Delivery Roller Unit (top pick-up mode)

- 1) Remove the body cover.
- 2) Remove the screw [1] and the spring [2]; then, disconnect the connector [3].

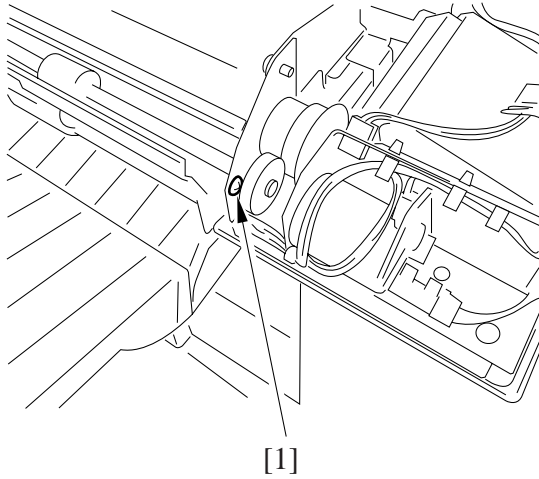

Figure 3-337a

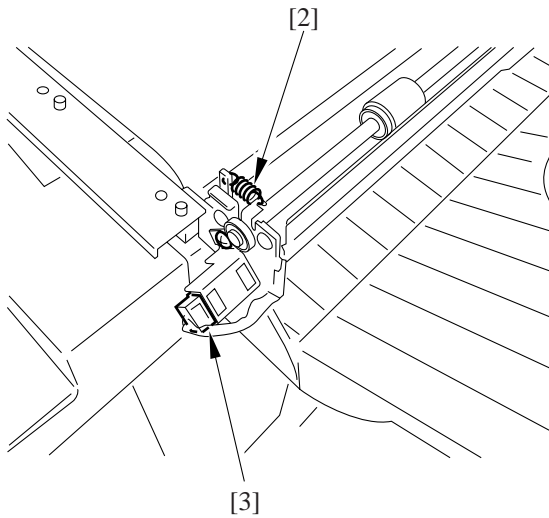

Figure 3-337b

- 3) Remove the two screws [4], and detach the timing belt [5] and the motor unit [6].

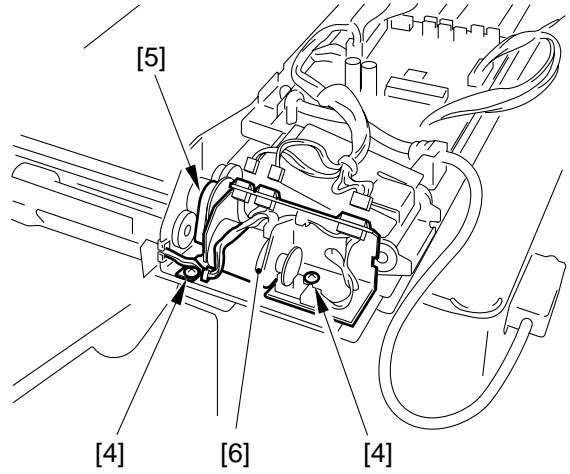

Figure 3-338

- 4) Remove the screw at the front and the two screws [8] at the rear; then, detach the delivery roller unit [9].

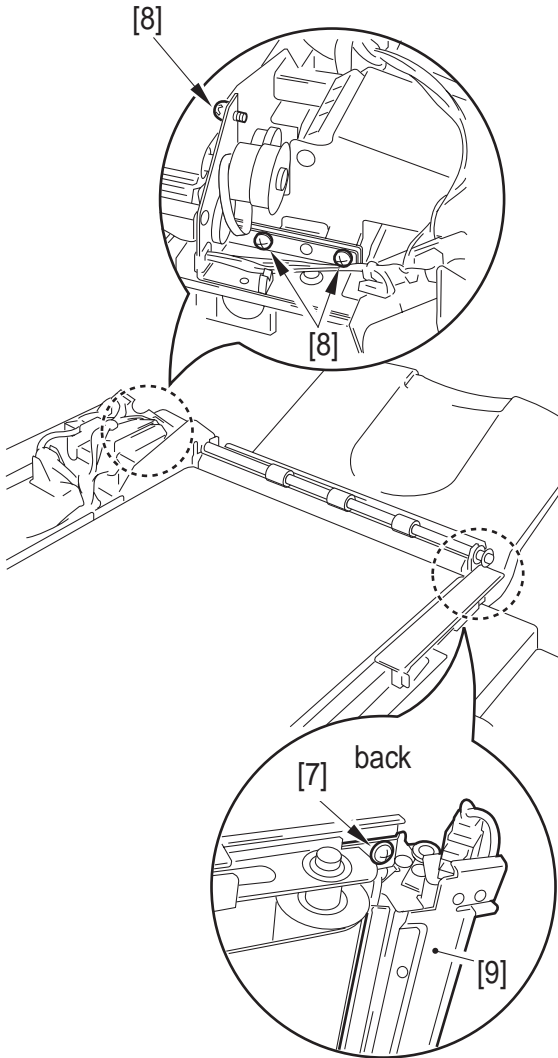

figure 3-339

## H. Reversing Guide

- 1) Remove the body cover.
- 2) Remove the gear [1] and the timing belt [2].

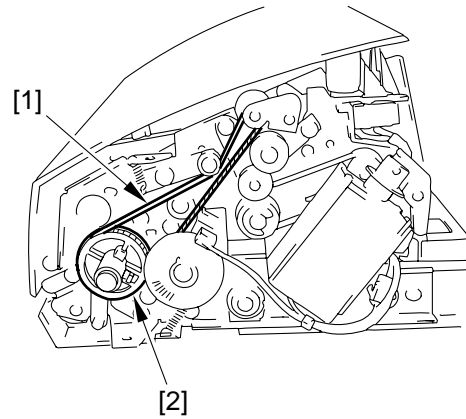

Figure 3I-340

**Reference:** \_\_\_\_\_  
Remove the gear while unlocking it.

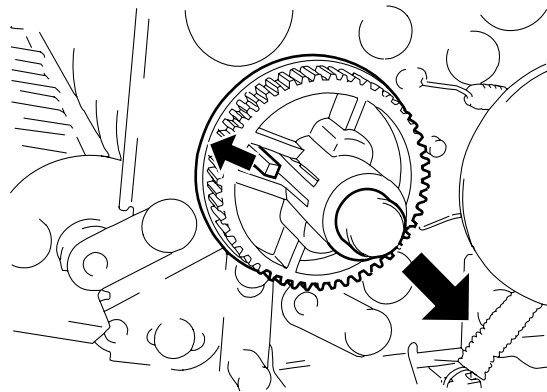

Figure 3-341



- 3) Disengage the front side [3] and the rear side [4] of the reversing guide spring.

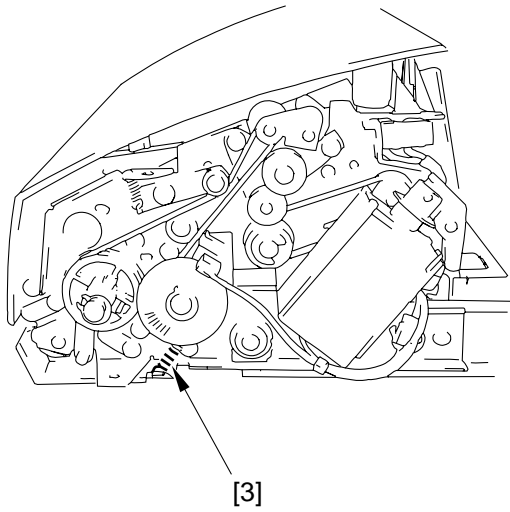

Figure 3-342

- 4) Remove the screw [5], and detach the solenoid unit [6].

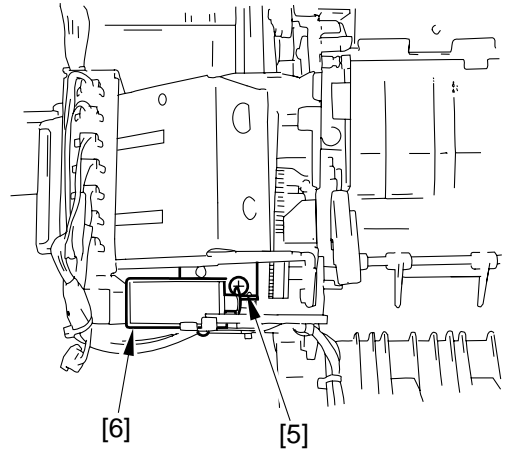

Figure 3-344

- 5) Remove the reversing sensor jack [7], and the grounding cord [8].

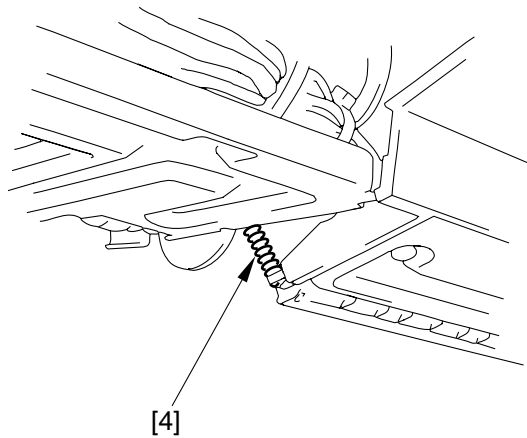

Figure 3-343

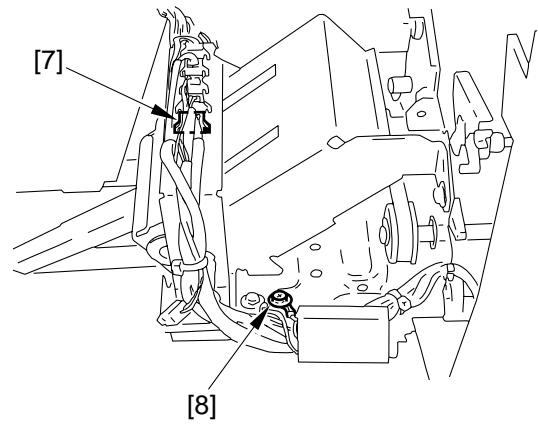

Figure 3-345

- 6) Remove the screw [9], screw [11], and fixing pin [12]; then, detach the reversing guide [13].

**Caution:**

When mounting the fixing pin, be sure that its position is as it was initially.

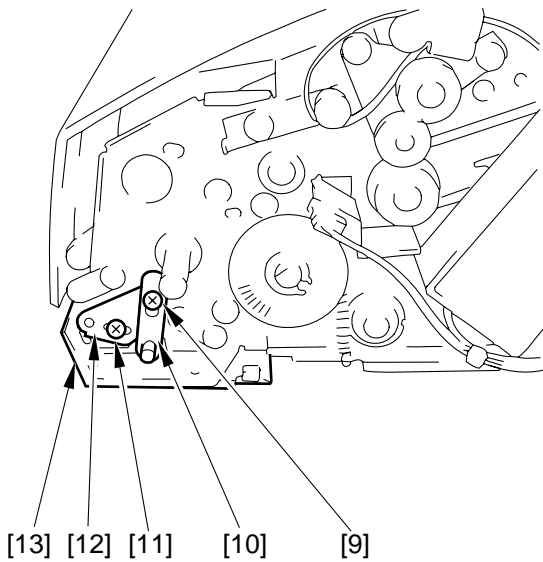

Figure 3-346

## I. Stopper Plate Solenoid

### 1. Removing the Stopper Plate Solenoid

- 1) Remove the body cover.
- 2) Remove the two screws [1], and remove the original tray mounting plate [2].

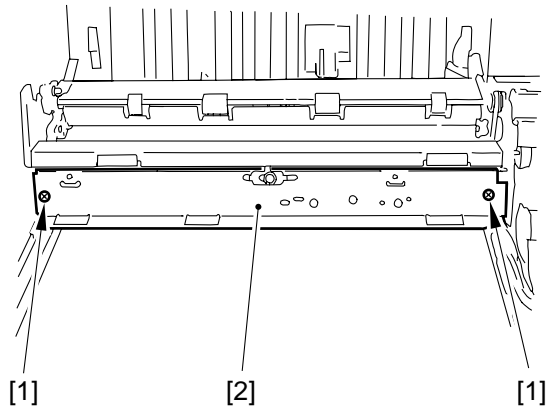

Figure 3-347

- 3) Remove the two screws, and disconnect the connector [4]; then, remove the stopper plate solenoid [5].

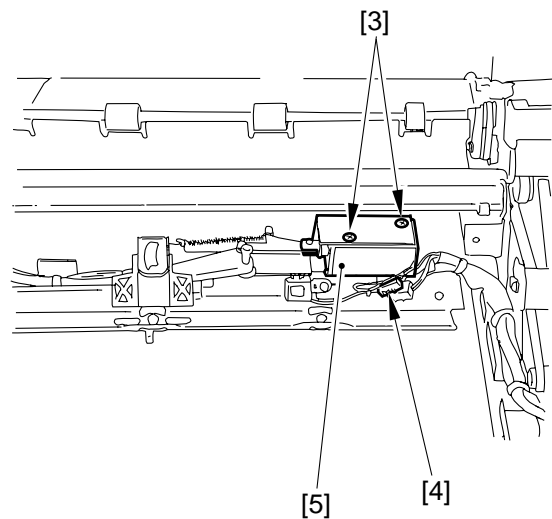

Figure 3-348

## 2. Making Adjustments

- 1) Secure the solenoid [1] in place where the stopper [3] (rubber block) butts against the rear edge of the stopper plate [2] when the plunger of the solenoid [1] is at the end of its stroke.

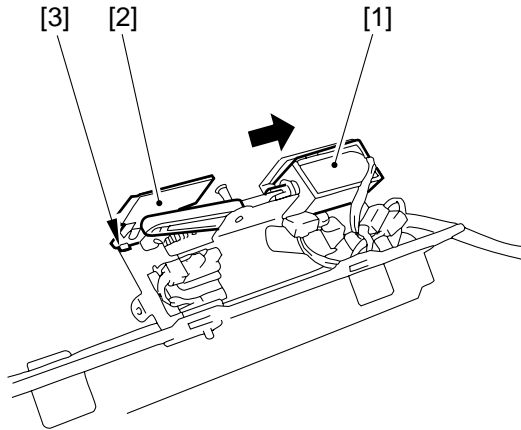

Figure 3-349

## J. Positioning the Paper Retaining Plate Solenoid (SL2)

- 1) Prepare test strips.  
Cut a sheet of A4 or LTR paper (64 g/m<sup>2</sup>) into widths of about 70 mm each.

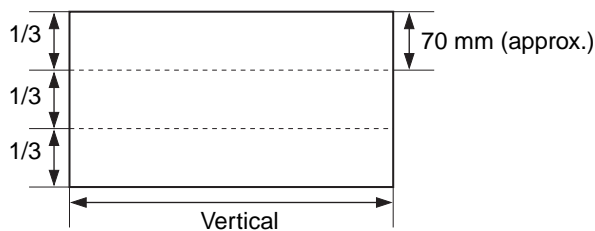

Figure 3-350

- 2) Remove the front cover and the cover.
- 3) Shift bits [5] and [6] of the DIP switch (DSW1) on the DADF controller to ON, and press the push switch.
  - The pick-up roller starts to rotate and will stop at the top pick-up mode pick-up position.
- 4) When the pick-up roller has stopped, press the push switch (SW3) on the DADF controller once again.
  - The motor will stop operation.
- 5) Secure the paper retaining solenoid in place so that the delivery roller [2] (pick-up roll for top pick-up mode) is in firm contact with the pick-up roll [3] when the plunger [1] of the paper retaining solenoid is fully pushed.

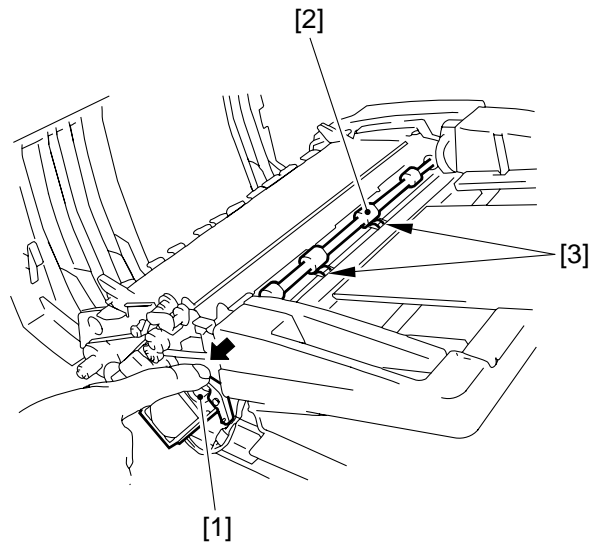

Figure 3-351

- 6) Push in a test strip prepared in step [1] between the delivery roller and the pick-up roller while pushing the plunger of the paper retaining solenoid fully. Check to make sure that the delivery roller rotates when the rear and the front pick-up roller is tested this way.

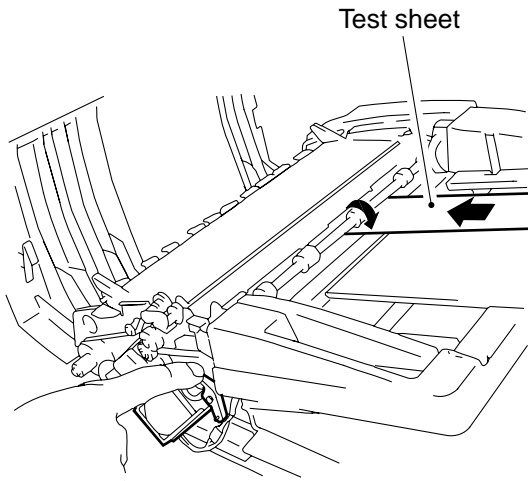

Figure 3-352

**Reference:**

When pulling the test strip, the one-way clutch will operate to hold the delivery roller from rotating.

- 7) If the delivery roll does not rotate when a test strip is pushed in, go back to step 3).
- 8) Shift the bits of the DIP switch (DSW1) on the DADF controller PCB back to initial configuration.

**K. Positioning the Paper Deflecting Solenoid (SL3)**

- 1) Remove the body cover.
- 2) Loosen the fixing screw [1], and tighten it when the stroke of the solenoid [2] is 4.5 mm.

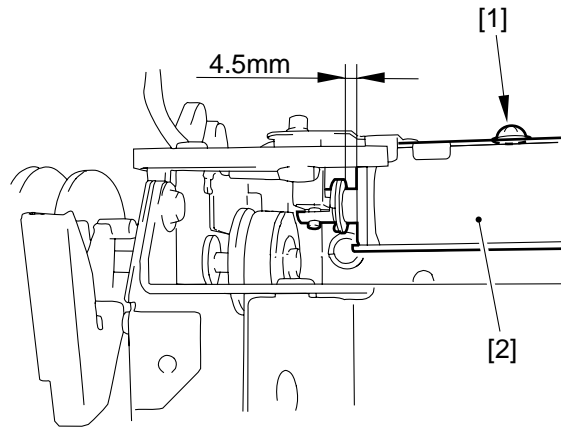

Figure 3-353

**L. Stamp Solenoid**

- 1) Remove the delivery roller unit (top pick-up mode).
- 2) Remove the screw [1] and spring [2]; then, detach the flapper plate [3].

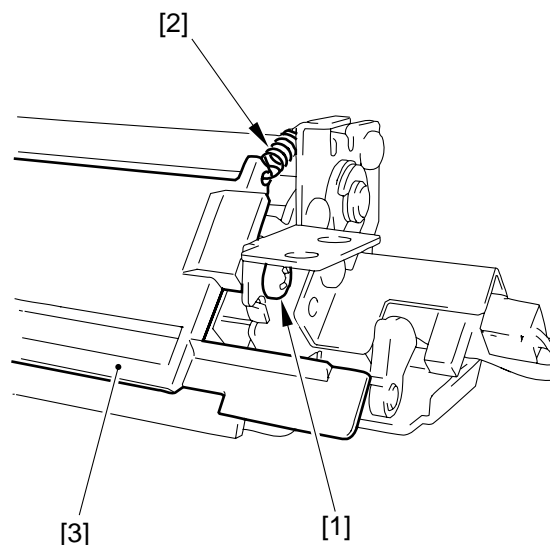

Figure 3-354

- 3) Remove the E-ring [4] and the bush [5].

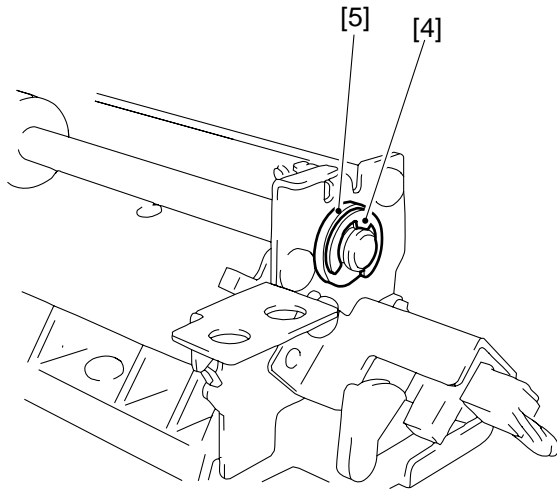

Figure 3-355

- 4) Remove the two E-rings [6], gear [7], and bush [8]; then, detach the delivery roller [9]. (Take care not to drop the pin.)

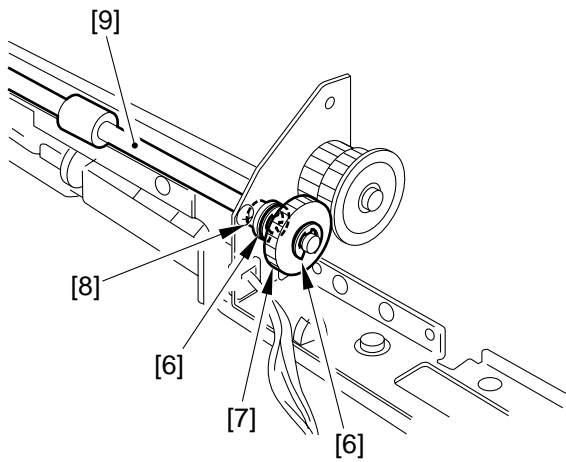

Figure 3-356

- 5) Remove the two screws [10] at the front and the two screws [11] at the rear; then, remove the paper guide plate [12].

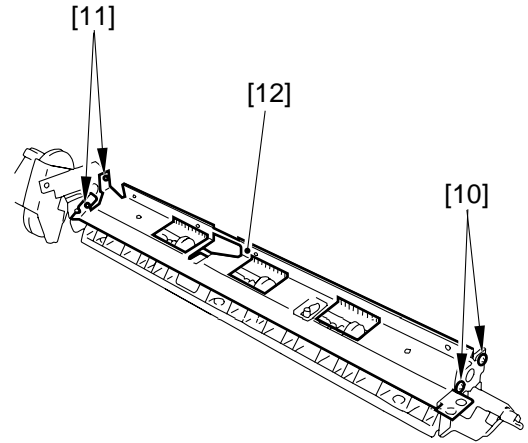

Figure 3-357

- 6) Remove the sensor flag [13], and disconnect the connector [14].

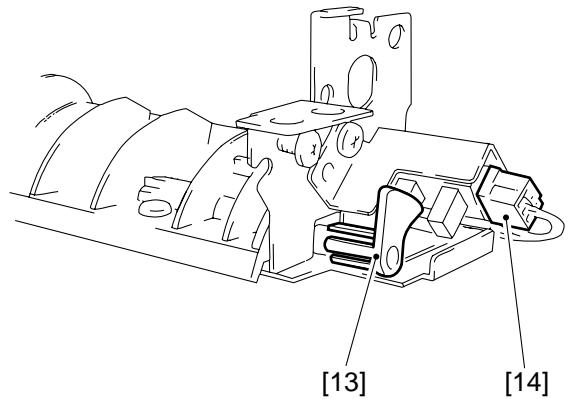

Figure 3-358

- 7) Remove the three screws [15], and detach the delivery roll mount [16].

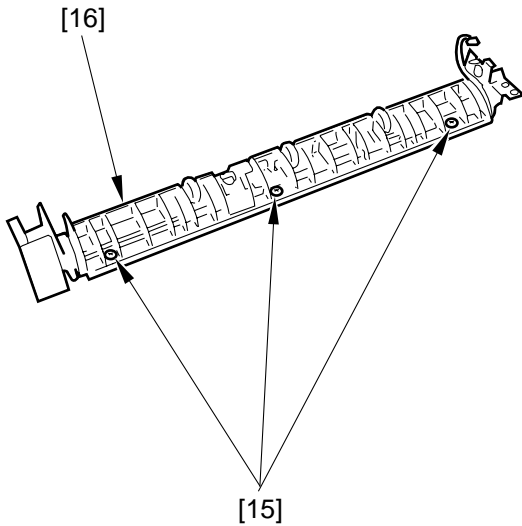

Figure 3-359

- 8) Remove the delivery roll [17], and detach the stamp solenoid mount [18].

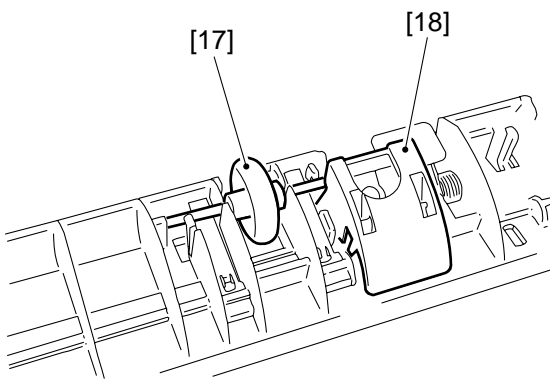

Figure 3-360

- 9) Disengage the two claws [20] of the stamp solenoid mount [18]; then, detach the stamp solenoid [19].

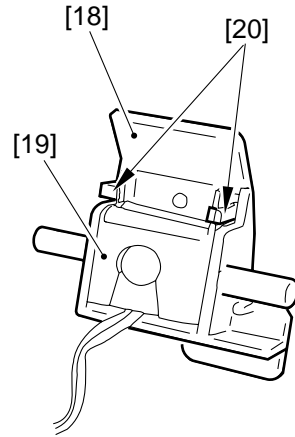

Figure 3-361

### M. Feeding Belt

- 1) Remove the body cover.
- 2) Remove the spring [1] at the front.

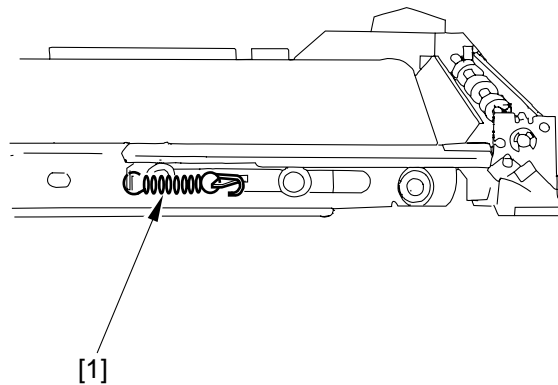

Figure 3-262

- 3) Free the spring [2] from the hook [3] at the rear, and engage it on the hook [4] designed to keep the spring temporarily.

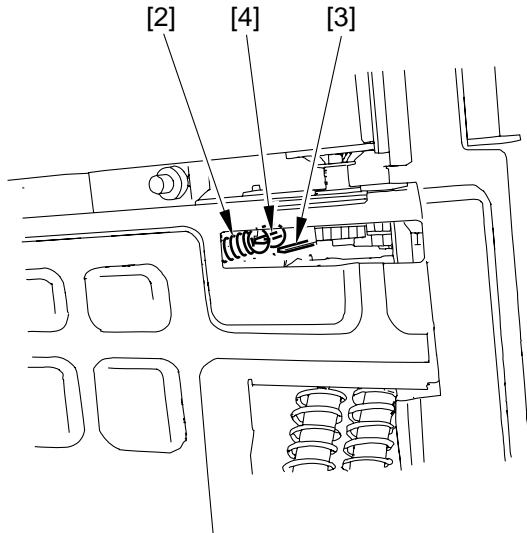

Figure 3-363

- 5) Remove the four screws [8], and detach the side plate [7].

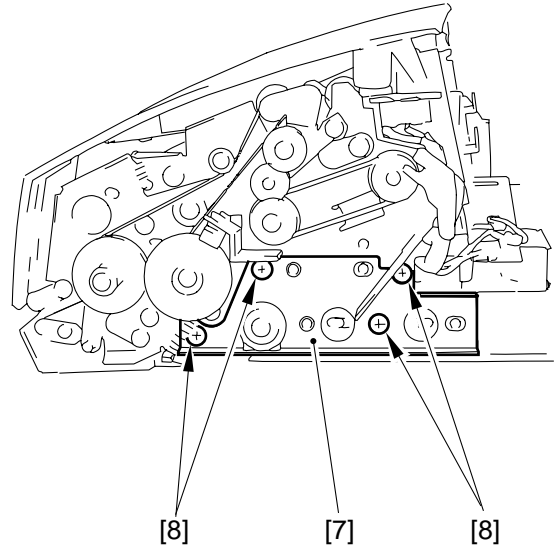

Figure 3-365

- 4) Remove the two screws [5], and detach the solenoid [6]. (Take care not to drop the pin in the solenoid arm.)

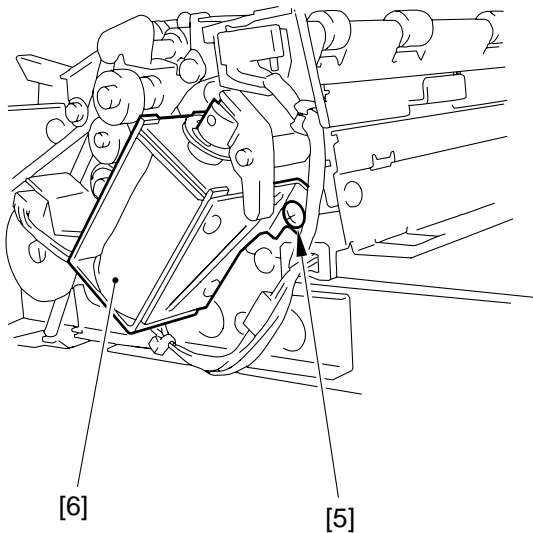

Figure 3-364

- 6) Remove the three screws [9], and detach the delivery unit linking plate [10].

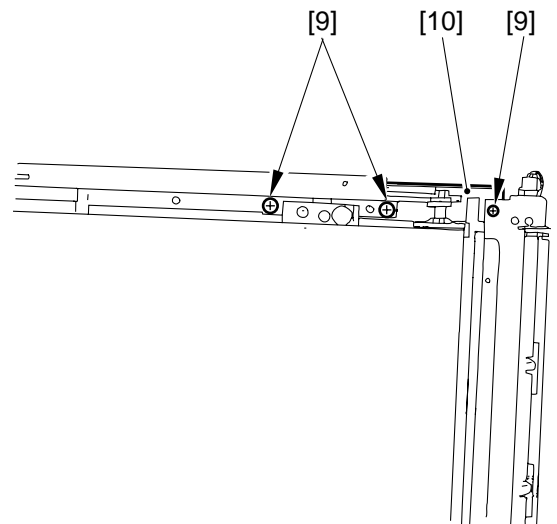

Figure 3-366

7) Pull off the feeding belt [11] to the front.

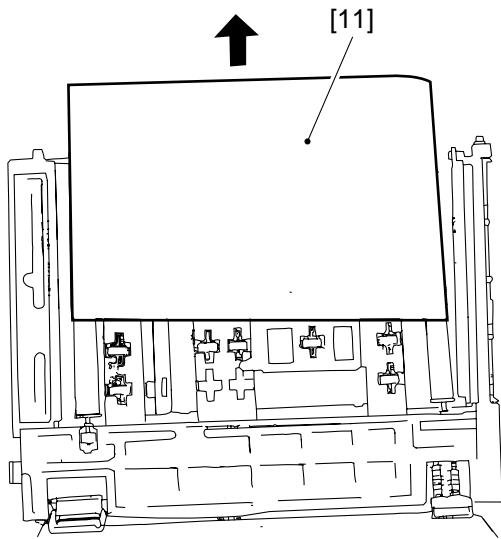

Figure 3-367



## IV. CLEANING

### A. Belt Assembly

- 1) Move the feeding belt in the direction of the arrow to dry wipe.

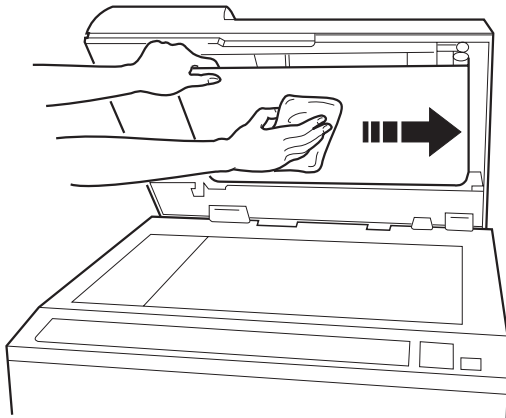

Figure 3-401

- 2) Place a sheet of copy paper whose center is moistened with alcohol on the original tray; then, shift bit 6 of the DIP switch (SW1) on the DADF controller PCB to ON.

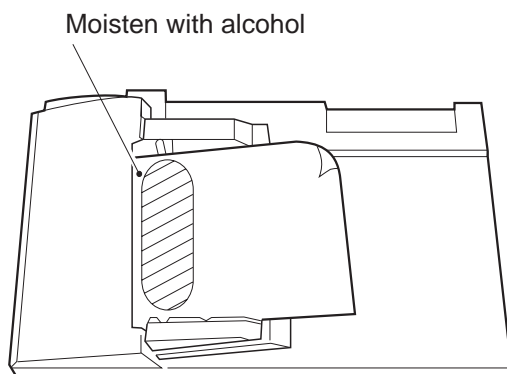

Figure 3-402

- 3) Press the push switch (SW3) to execute cleaning of the separation belt.
- 4) When cleaning has ended, press the push switch (SW3), and shift all bits of the DIP switch to OFF.
- 5) Mount the DADF controller cover.

### B. Sensors

The machine's feeding path is equipped with two transmission type sensors (original sensor S1, registration sensor S3) and three photointerrupters (pick-up sensor S7, delivery sensor S6, reversal sensor S8).

The light-receiving face of a transmission type sensor tends to collect more paper lint than a photointerrupter, possibly leading to malfunction. The sensors may be cleaned as follows:

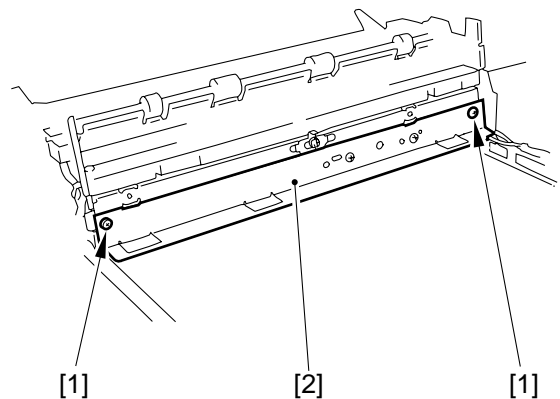

Figure 3-403

- 2) Clean the sensor S1 [3] shown in the following figure.

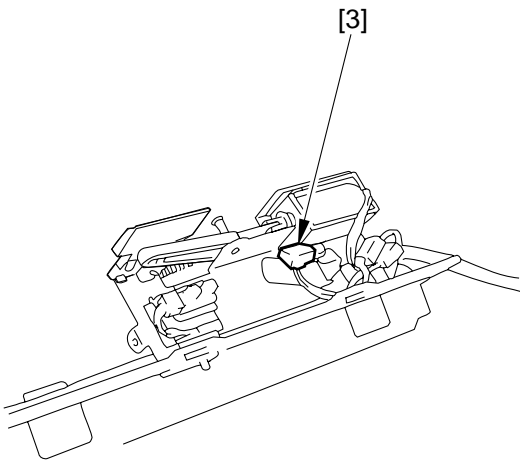

Figure 3-404

**2. Reflecting Face (original sensor)**

- 1) Clean the reflecting face [2] of the original sensor while keeping the delivery roller [1] down.

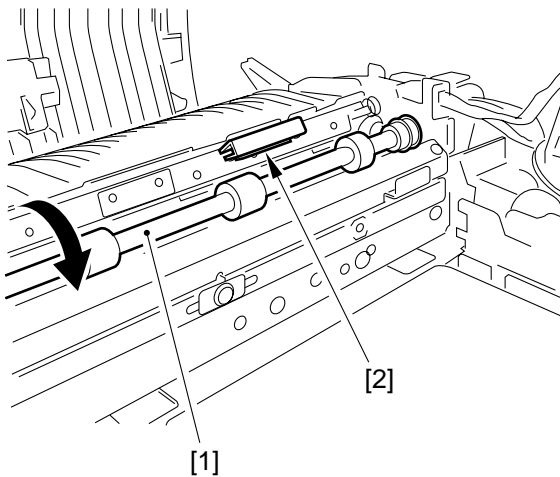

Figure 3-405

**3. Registration Sensor (S3)**

- 1) Remove the separation belt unit.
- 2) Remove the four screws [2], and detach the separation guide plate [1].

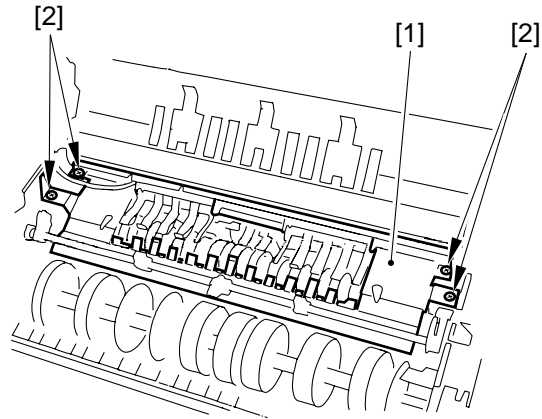

Figure 3-406

- 3) Remove the two screws [4], and detach the inside guide plate.

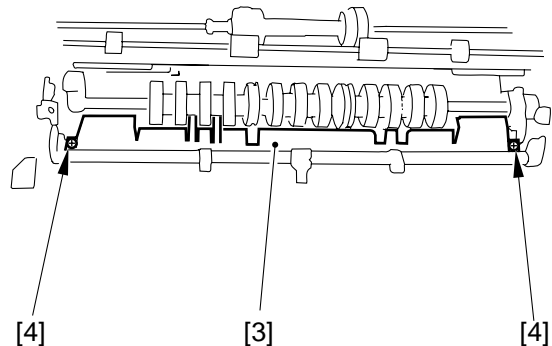

Figure 3-407

- 4) Clean the registration sneers S3 [4] mounted on the inside the plate [3].

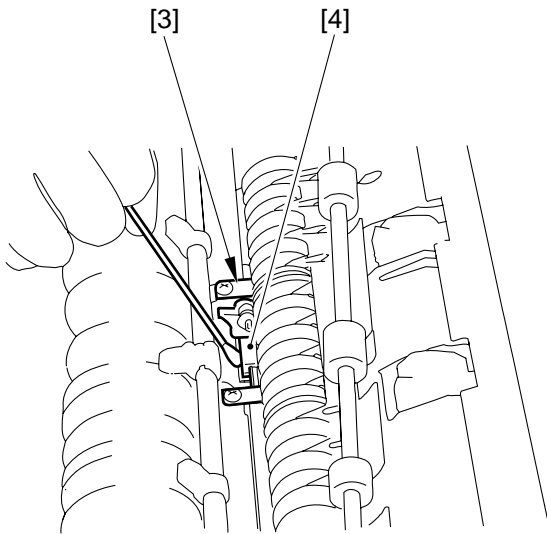

Figure 3-408

**4. Registration Sensor LED3**

- 1) Remove the screw [3], and detach the registration sensor LED3 cover [2] of the reversing roller unit [1].

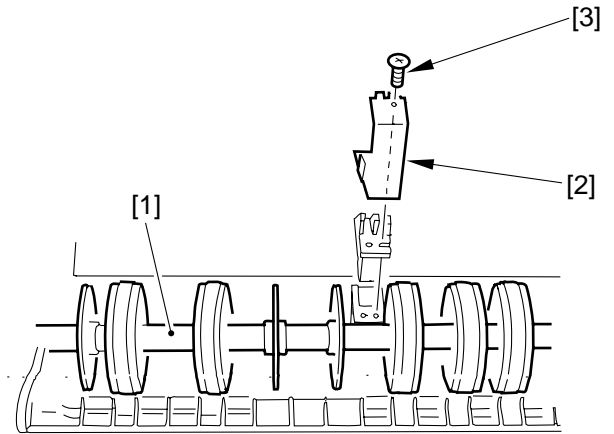

Figure 3-409

- 2) Clean the light-emitting face of the registration sensor LED3 [4].

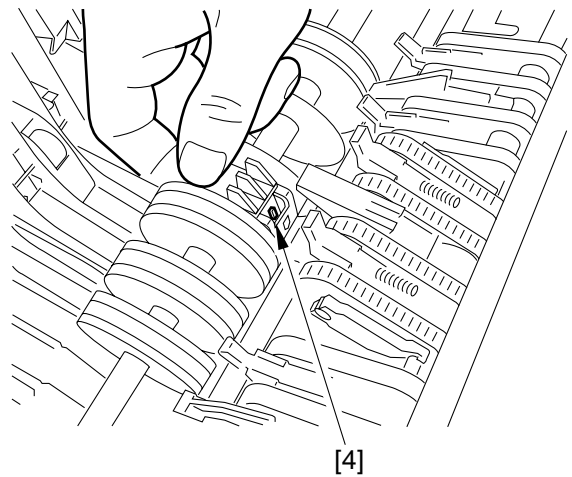

Figure 3-410

### C. Separation Guide

- 1) Remove the separation belt unit. (See the instructions given for the separation belt unit.)
- 2) Remove the front separation flapper and the front separation flapper. (See the instructions given for the separation flapper.)
- 3) Clean the areas (12 in all) of the pre-separation guide with alcohol.
  - Be sure to keep the strokes in the direction of feeding.

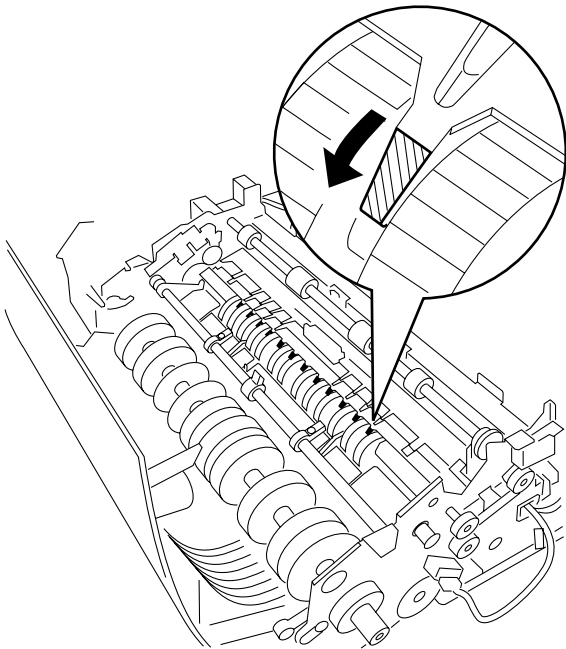

Figure 3-411

## V. FEEDING

The machine does not have parts requiring periodical lubrication. Apply lubricant if you have replaced gears or the like.

**Caution:**

When applying lubricant, take care that the timing belt and the cable is not soiled with lubricant. Otherwise, be sure to wipe the part clean.

### A. Pick-Up Drive Assembly

Apply lubricant to the following parts.

#### 1. Rear

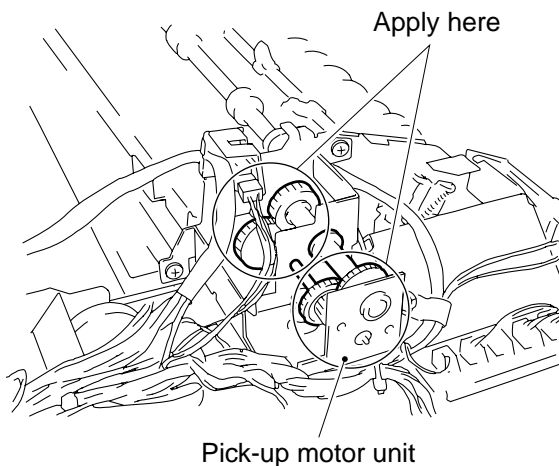

(\*CK-0551-020)

**Figure 3-501**

\*Tool No

#### 2. Front

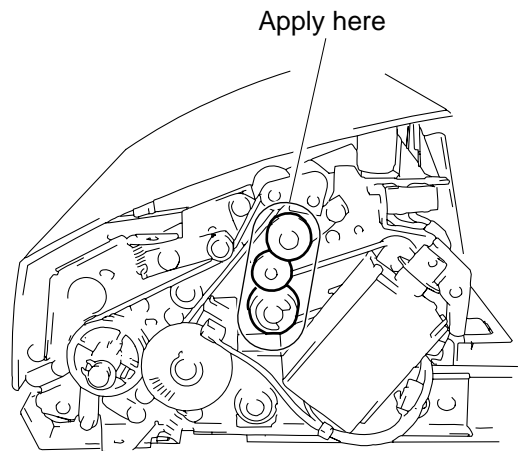

(\*CK-0551-020)

**Figure 3-502**

### B. Right Delivery Drive Assembly

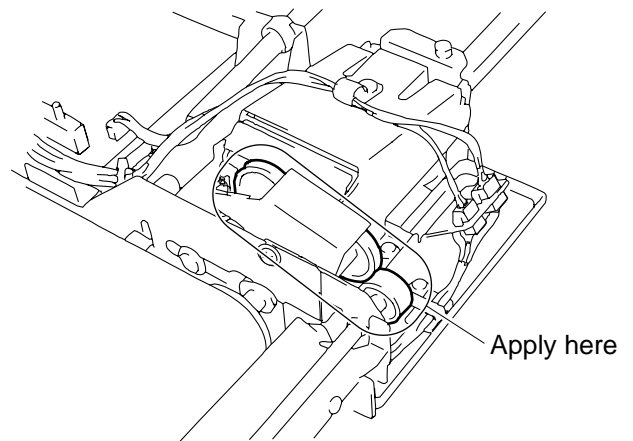

(CK-0551-020)

**Figure 3-503**



---

# CHAPTER 4

---

## MAINTENANCE AND SERVICING

---

I. PERIODICALLY REPLACED PARTS .....	4-1	III. SCHEDULED SERVICING CHART .....	4-2
II. CONSUMABLES AND DURABLES .....	4-1		





## I. PERIODICALLY REPLACED PARTS

The machine does not have parts that require periodical replacement.

## II. CONSUMABLES AND DURABLES

Some parts of the machine may have to be replaced once or more because of wear or damage over the period of warranty. Replace them as necessary.

As of Dec. 1998

No.	Parts name	Parts No.	Q'ty	Life (copies)	Remarks
1	Feeding belt	FC1-7815-000	1	200,000	Replace if dirt cannot be removed.
2	Pick-up roller	FF5-5191-000	2	500,000	
3	Feeding belt (for top pick-up mode)	FB3-5702-000	4	25,000	
4	Separation roller (for top pick-up mode)	FF5-5207-000	1	500,000	

**Table 4-201**

**Note:**

The values in the table are estimates only, and are subject to change based on future data.

### III. SCHEDULED SERVICING CHART

**Caution:**

Do not use solvents or oils other than those indicated herein.

△ : Clean ● : Replace × : Lubricate □ : Adjust ⊙ : Inspect

Ref.	Parts name	Intervals (copies)		Remarks
		every 100,000	every 200,000	
1	Delivery/reversing roller	△		Replace if dirt cannot be removed
2	Registration roller	△		
3	Registration paper sensor (S3)		△	
4	Separation belt (pick-up assembly)	△		
5	Feeding roller (pick-up assembly)	△		
6	Original tray paper sensor (S1)		△	
7	Delivery roller (for top separation mode)	△		
8	Pick-up roller (pick-up assembly)		△	
9	Feeding belt	△		
10	Copyboard glass retainer (right)	△		
11	Copyboard glass	△		
12	Pre-separation guide	△		Or 6 months, whichever is earlier.
13	Vertical size plate	△		

Table 4-301

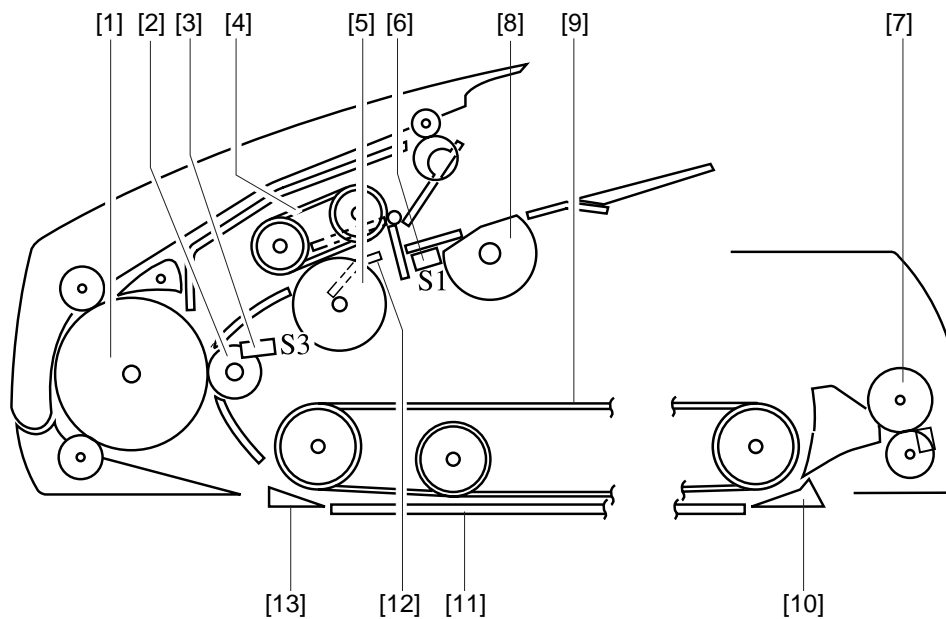

Figure 4-301

---

# CHAPTER 5

---

## TROUBLESHOOTING

---

I. STANDARDS AND ADJUSTMENTS .....	5-1	IV. VARIABLE RESISTORS, LIGHT-EMITTING DIODES, AND CHECK PINS BY PCB .....	5-23
A. Mechanical System .....	5-1	A. DADF Controller PCB .....	5-23
B. Electrical System .....	5-11	B. Indicator PCB .....	5-25
II. TROUBLESHOOTING .....	5-15	C. DIP Switch Functions .....	5-26
A. Troubleshooting Malfunctions..	5-15	V. SELF DIAGNOSIS .....	5-28
III. ARRANGEMENT OF THE ELECTRICAL PARTS .....	5-20	A. DADF Self Diagnosis .....	5-28
A. Motors, Solenoids, and Sensors .....	5-20		
B. PCB .....	5-22		



# I. STANDARDS AND ADJUSTMENTS

## A. Mechanical System

### 1 Adjusting the DADF Height

- 1) Remove the copier's rear cover.  
Turn the bolt of the left/right support so that the distance *a* between the two rubber feet at the rear and the horizontal size plate on the copyboard glass is  $0.2 \pm 0.1$  mm (about two sheets of copy paper of  $64 \text{ g/m}^2$ ) when the DADF is closed, i.e., the feet at the front are in contact with the copyboard glass.  
After adjustment, tighten the nuts to lock them.

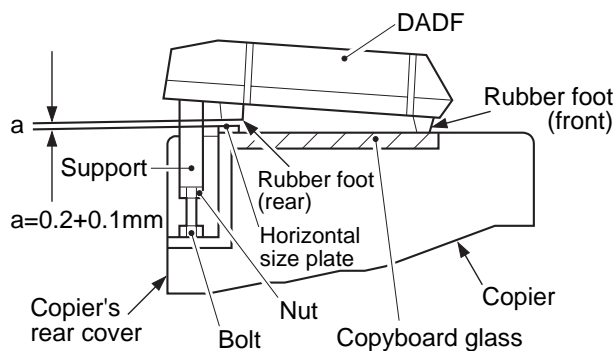

Figure 5-101

- 2) After adjustment, check to make sure that both left and right rubber feet at the front of the DADF are in contact with the copyboard glass. Otherwise, adjust the height of the magnet at the front.

### 2 Adjusting the Original Stop Position

Adjust the original stop position after "adjusting the DADF height"; then, perform "correcting the skew," "adjusting the distance to the horizontal size plate," and "adjusting the original leading edge stop position."

#### a. Correcting the Skew

- 1) Remove the screw, and detach the DADF controller cover.

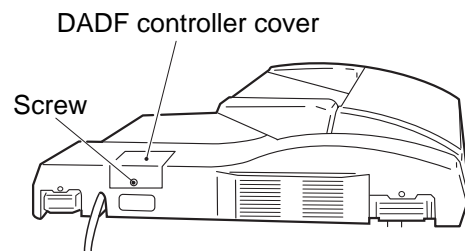

Figure 5-102

- 2) Shift bit 1 of the DIP switch (DSW1) on the DADF controller PCB to ON.

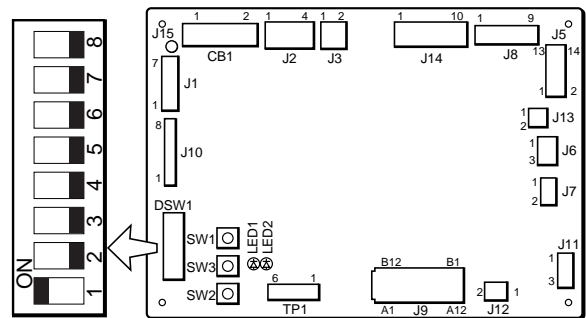

Figure 5-103

- 3) Place an A3 or  $279.4 \times 431.8$ -mm ( $11 \times 17$ ") sheet of copy paper ( $64 \text{ g/m}^2$ ) on the original tray.

- 4) Press the push switch (SW3) on the DADF controller PCB once.
  - The copy paper will be picked up and stopped on the copyboard glass.

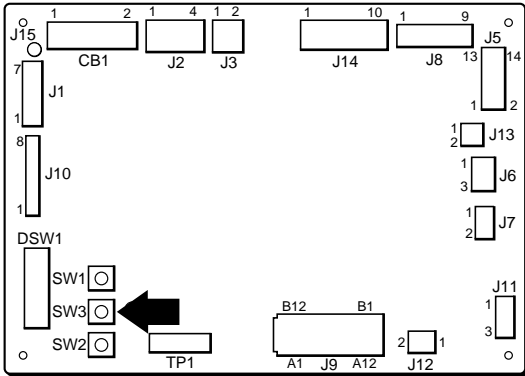
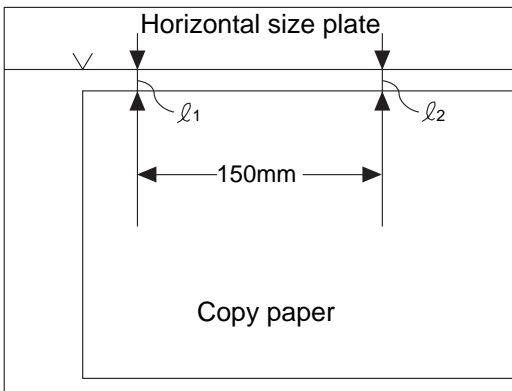

Figure 5-104

- 5) Open the DADF slowly, and check to make sure that the difference between  $l_1$  and  $l_2$  shown in the figure is within 1 mm.



Standard:  
 $l_1 - l_2 = 0 \pm 1 \text{ mm}$

\* $l_1$  may be anywhere on the copy paper.

$$l_1 - l_2 = 0 \pm 1 \text{ mm}$$

Figure 5-105

- 6) If the difference is not as indicated, loosen the nut at the rear of the right hinge unit, and turn the adjusting screw to make adjustments.

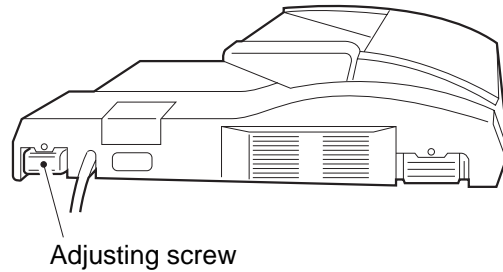

Figure 5-106

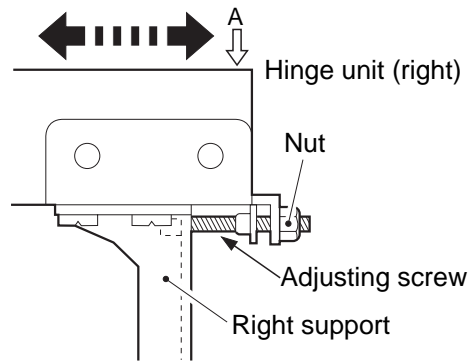

Figure 5-107

- Relationship between the Adjusting Screw and  $l_1/l_2$

Direction of turn	Relationship
Clockwise	$l_1 < l_2$
Counterclockwise	$l_1 > l_2$

Table 5-101

- 7) After adjustment, tighten the nut to lock the adjusting screw in place.

- b. Adjusting the Distance to the Horizontal Size Plate  
Be sure to perform "removing the skew" before adjusting the distance to the horizontal size plate.

- 1) Shift bit 1 of the DIP switch (DSW1) on the DADF controller PCB to ON.

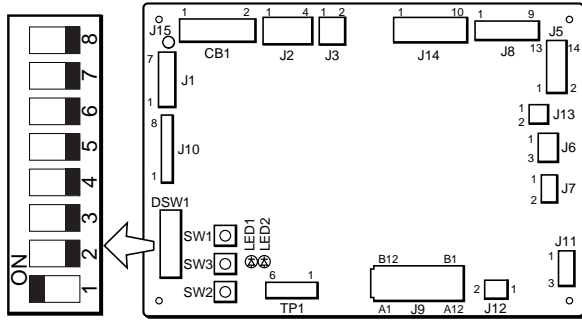

Figure 5-108

- 2) Place an A3 or 279.4×432.8-×mm (11"×17") sheet of copy paper (64 g/m<sup>2</sup>) on the copyboard tray.  
3) Press the push switch (SW3) on the DADF controller PCB once.
- The copy paper will be picked up and stopper on the copyboard glass.

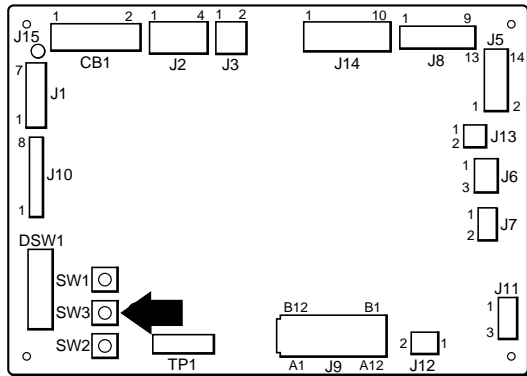

Figure 5-109

- 4) Open the DADF slowly, and check to make sure that the distance  $l_3$  shown in the figure is as indicated.

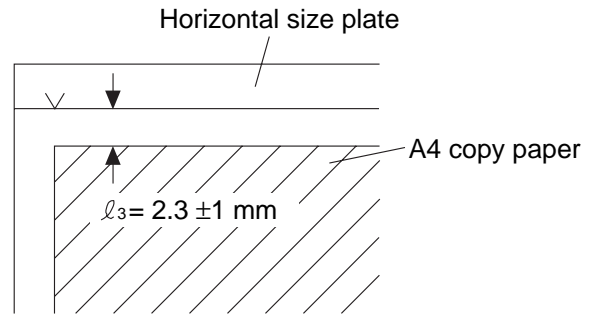

Figure 5-110

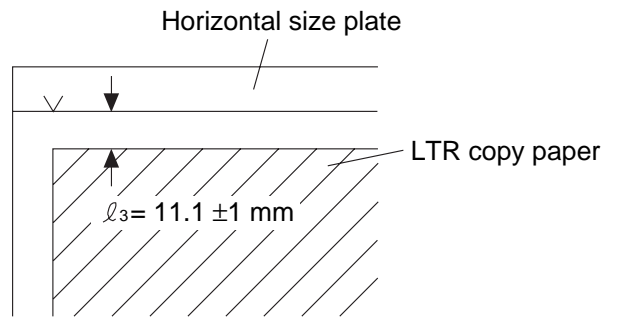

Figure 5-111

- 5) If not as indicated, loosen the positioning screw and the fixing screws of the DADF original tray, and adjust the position of the DADF original tray.

**Caution:**

When making a test copy, be sure to tighten the two fixing screws and the positioning screw (2 pc.). Otherwise, the original can jam.

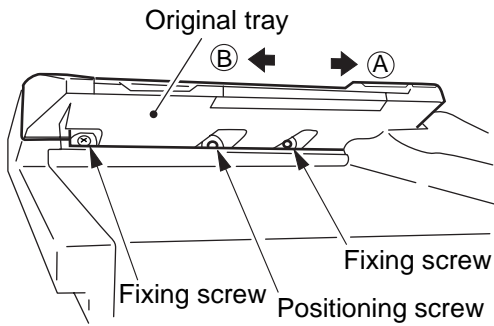

Figure 5-112

- Relationship between the DADF Original Tray and  $l_3$

Direction of shift	$l_3$
1	Decreases
2	Increases

Table 5-102

- After adjustment, check to make sure that the positioning screw and the fixing screws are fully tightened.

c. Adjusting the Original Leading Edge Stop Position

Be sure to perform "correcting the original skew" and "adjusting the distance to the horizontal size plate" before adjusting the original leading edge position.

1. Top Pick-Up Mode

- Shift bits 1, 4, and 5 of the DIP switch (DSW1) on the DADF controller PCB to ON.

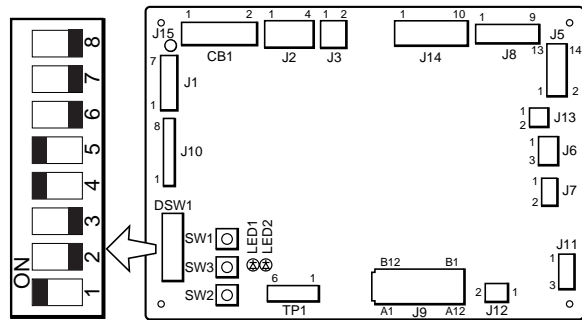

Figure 5-113

- Place an A3 or 279.4x432.8-mm (11"x17") sheet of copy paper (64 g/m<sup>2</sup>) on the original tray.
- Press the push switch (SW3) on the DADF controller PCB once.
  - The copy paper will be picked up and stopped on the copyboard glass.

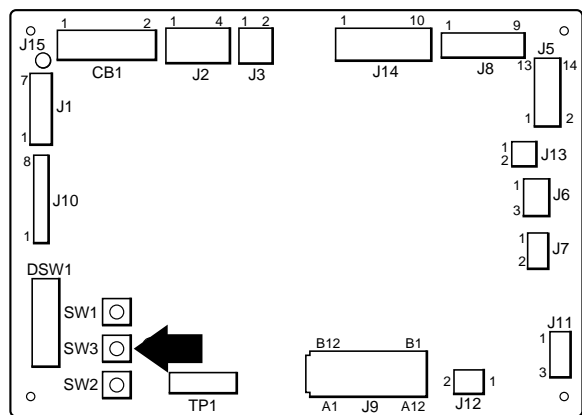
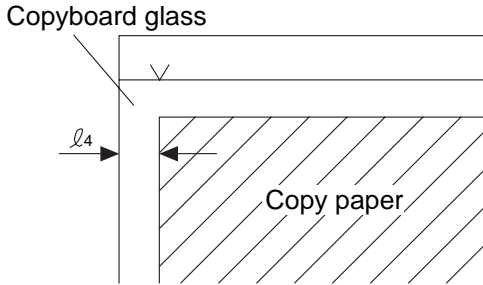

Figure 5-114



- 4) Open the DADF slowly, and measure the copy paper stop position  $l_4$ ; then, close the DADF.



Standard:  $l_4 = 11.0 \pm 1$  mm

Figure 5-115

- 5) To adjust the original leading edge stop position, use the push switches (SW1 and SW2) on the DADF controller PCB. Each press on the push switch will shift the original stop position by 0.34 mm. When the correct position is attained, press the push switch (SW3) once. The copy paper will be discharged and the new setting will be stored.

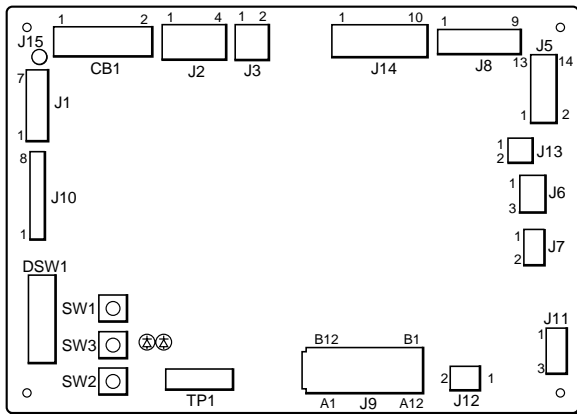

Figure 5-116

- Push Switch and Shift

Push switch	Direction of shift
SW1	Rear
SW2	Front

Table 5-103

**Note:** Holding down the push switch will not cause more than a single shift.

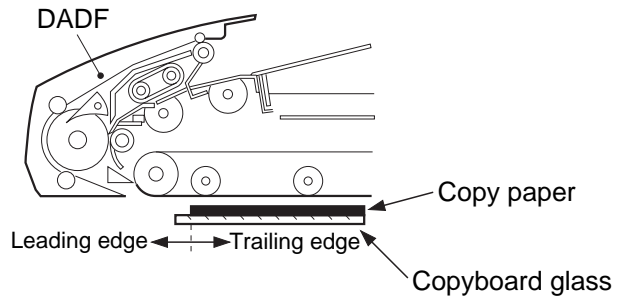

Figure 5-117

<EX.>

Suppose that the copy paper stop position  $L_4$  is 10 mm from the edge of the copyboard glass when the push switch (SW3) on the DADF control PCB has been pushed once to stop the copy paper on the copyboard glass and the DADF has been opened.

Close the DADF slowly without removing the copy paper,

To shift the copy paper stop position toward the rear by 1.6 mm,

$$1.6 \text{ mm} / 0.34 \text{ (adjustment pitch)} = 4.70$$

the push switch (SW1) should be pressed five times.

Press the push switch (SW1) five times, and press the push switch (SW3) on the DADF controller PCB once so that the copy paper will be discharged and the new setting will be stored in memory.

**3 Adjusting the Sheet-to-Sheet Distance for Reduced Page Composition Mode**

Be sure to perform "adjusting the DADF height" and "adjusting the original stop position" before adjusting the sheet-to-sheet distance for reduced page composition mode.

a. Top Pick-Up Mode

DADF model	Originals size (in feeding length)
A/B	220 to 250 mm
Inch	220 to 260 mm

**Table 5-104**

- Shift bits 1, 2, and 4 of the DIP switch (DSW1) on the DADF controller PCB to ON.
- Place two sheets of A4 or LTR copy paper (64 g/m<sup>2</sup>) on the original tray. Be sure that the copy paper matches the DADF model: if A/B-configuration, use A4 copy paper; if Inch-configuration, use LTR cop paper.

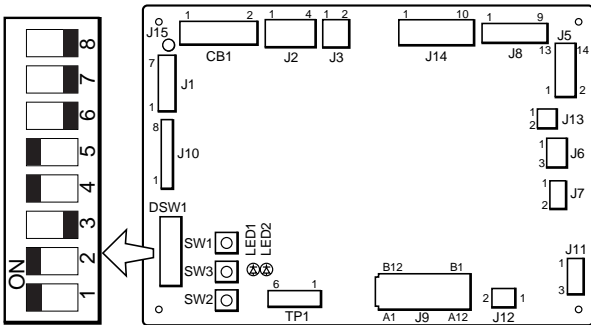

**Figure 5-118**

- Press the push switch (SW3) on the DADF controller PCB one.
  - The copy paper will be picked up and stopped on the copyboard glass.
- Open the DADF slowly, and measure the distance  $\ell_5$  between the two sheets of copy paper. Then, close the DADF.

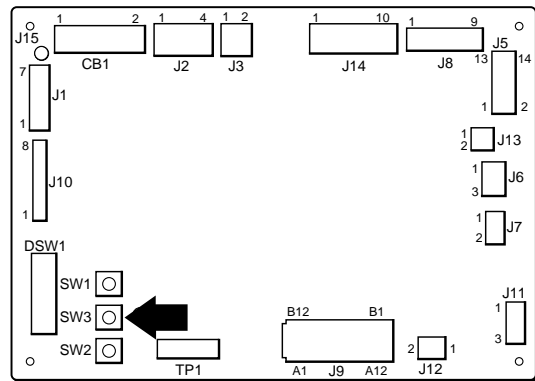

**Figure 5-119**

- Use the push switches SW1 and SW2 on the DADF controller PCB to adjust the sheet-to-sheet distance.

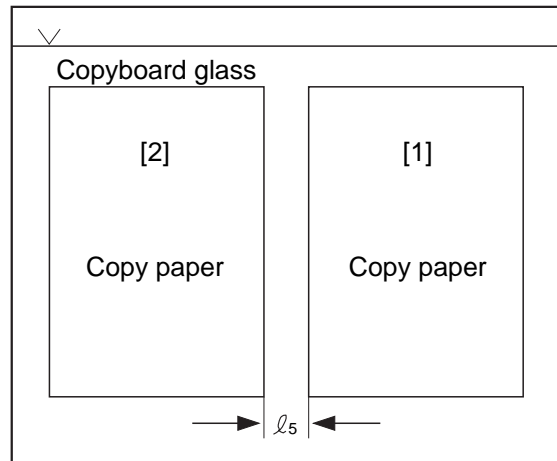

Standard:  $\ell_5 = 0 \pm 3$  mm

**Figure 5-120**

A single press on each push switch will shift the copy paper [2] of Figure 5-128 by 0.34 mm. When the position is as desired, press the push switch SW3 once to discharge the copy paper and store the new setting.

<EX.>

- Relationship between Push Switches and Sheet-to-Sheet Distance

Push switch	Sheet-to-sheet distance $\ell_3$
SW1	Increases
SW2	Decreases

Table 5-105

Suppose that the distance between the two sheets of copy paper is 4 mm when the push switch SW3 on the DADF controller PCB is pressed once to stop the copy paper on the copyboard and the DADF is opened.

To decrease the sheet-to-sheet distance by 4 mm,

$$4/0.34 \text{ (adjustment pitch)} = 12.12$$

the push switch SW2 must be pressed 12 times.

When the push switch SW2 is pressed 12 times and the push switch SW3 on the DADF controller PCB is pressed once, the copy paper will be discharged and the new setting will be stored.

- After "correcting the original skew," "adjusting the horizontal size plate," "adjusting the original leading edge stop position," and "adjusting the reduced composition mode sheet-to-sheet distance," turn off the copier and shift all bits of the DIP switch DSW1 to OFF.

Turn on the copier, and check to make sure that the operation of the DADF is normal.

However, if the size of the original (length in feeding direction) is as follows, keep bit 7 of the DIP switch DSW1 to ON.

DADF model	Original size (length in feeding direction)
A/B configuration	220 to 250 mm
Inch-configuration	220 to 260 mm

Table 5-106

**4 Adjusting the DADF Open/Closed Switch (MS1)**

- 1) Remove the body cover (upper).
- 2) Adjust the retaining plate so that the DADF switch MS1 turns on and off when the distance from the copyboard glass to the end of the DADF is 10 to 100 mm (open and close the DADF).

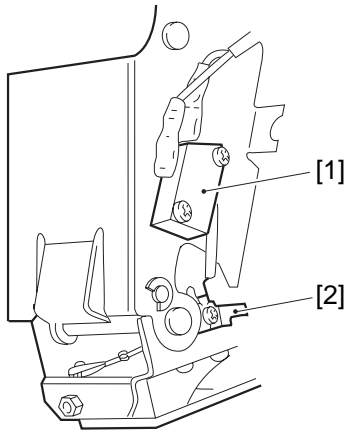

**Figure 5-121 Right Hinge**

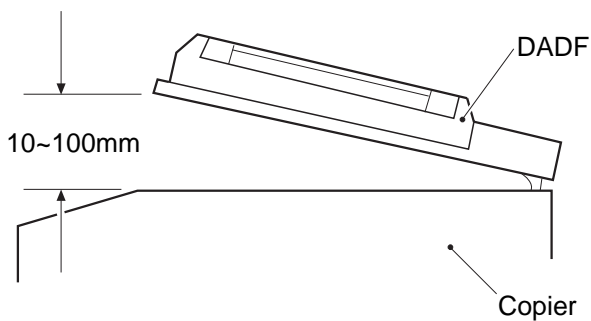

**Figure 5-122**

**5 Adjusting the Separation Belt Pressure**

- a. Outline
 

If originals start to move skew because of wear on the separation belt or the feeding roller, the pressure of the separation belt will have to be adjusted.

If the separation belt or the feeding roller must be replaced, be sure to make the following adjustments:

b. Before the Work

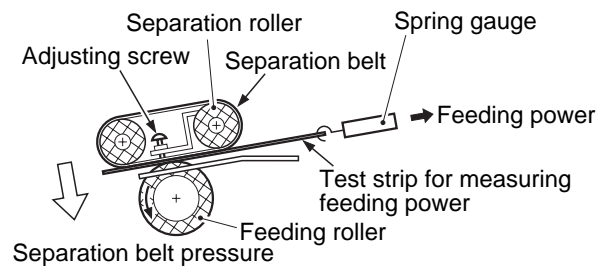

**Figure 5-123**

- 1) Prepare test strips for measuring feeding power.
 

Cut an A4 or LTR sheet of copy paper (64 or 80 g/m<sup>2</sup>) into strips of about 70 mm; then, paste tape on both sides of the end of each, and put a hole.

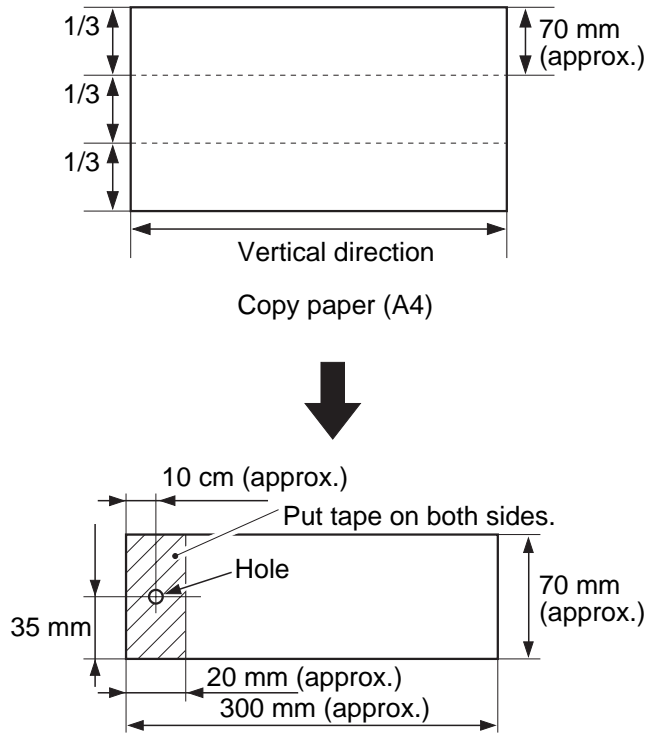

Figure 5-124

c. Top Pick-Up Mode

- 1) Remove the screw, and detach the DADF controller cover of the DADF.

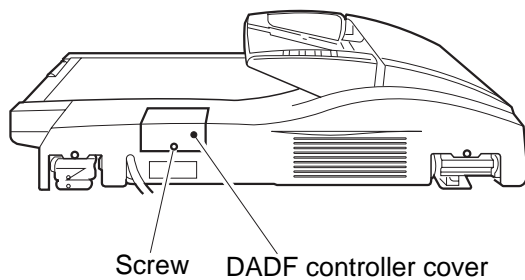

Figure 5-125

- 2) Shift bits 5 and 6 of the DIP switch DSW1 on the DADF controller PCB to ON to select separation belt/feeding roller cleaning mode (top pick-up).

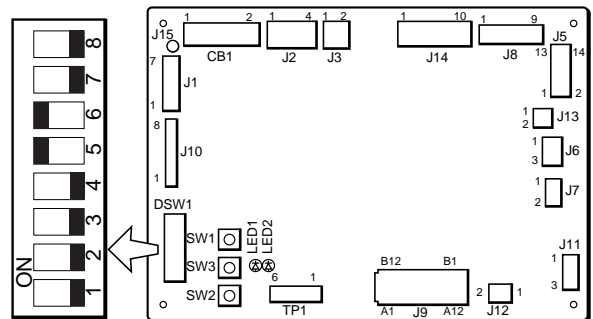
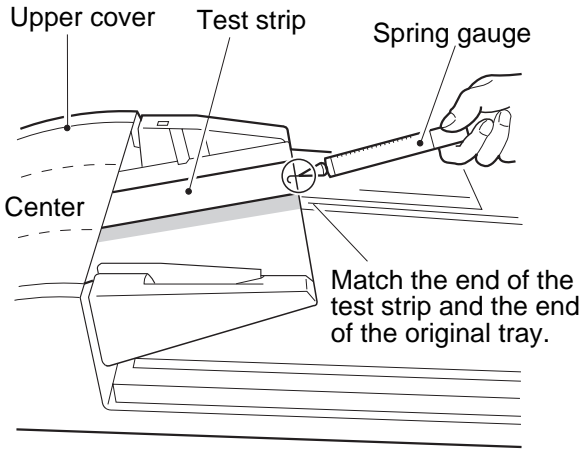

Figure 5-126

- 3) Press the push switch SW3 on the DADF controller PCB. Put the test strip into the middle separation assembly, and measure the feeding power (Figure 5-141).

**Points to Note When Taking Measurements**

1. Be sure that the three separation belts are in contact with the test strip.
2. Be sure that the test strip is pulled straight along the separation belt (Figure 5-131).
3. Be sure that measurements are taken when the rear end of the test strip and the rear end of the original tray are flush (Figure 5-141).



Spring gauge  
(capable of measuring about 600 g; CK-0058)

**Figure 5-126**  
**Measuring the Feeding Power (middle)**

- 4) Open the upper cover of the DADF to end measurement.
- 5) Press the push switch SW3 on the DADF controller PCB once (at the front, glued in place).

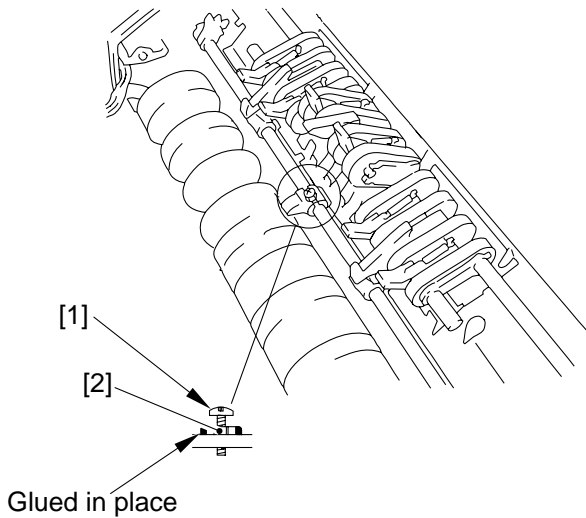

**Figure 5-128**

Test strip	Feeding power (g)
64 g/m <sup>2</sup>	300±30
80 g/m <sup>2</sup>	330±30

**Table 5-107**

Direction of rotation	Feeding power (g)
Clockwise	Decreases
Counterclockwise	Increases

**Table 5-108**  
**Adjusting Screw and Feeding Power**

- 6) Be sure that LED1 and LED2 on the DADF controller PCB are on and the voltage of TP1-1 is 1.1±0.1 V and the voltage of TP1-2 is 4.1± 0.2 V.  
If the voltage of either TP1-1 or TP1-2 is not as indicated, suspect displacement of the light-emitting/-receiving unit of the sensor corresponding to the test probe; check the position of the sensor.

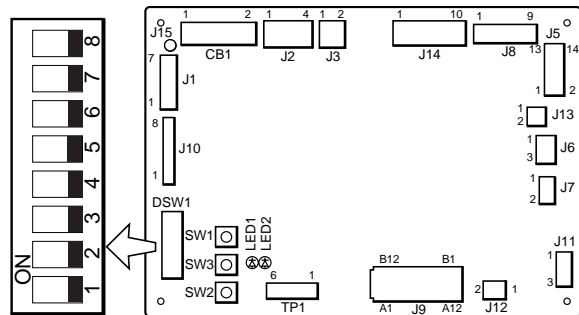

**Figure 5-129**

## B. Electrical System

### 1. Replacement of Major Parts

Major parts	Description
DADF controller PCB	<ol style="list-style-type: none"> <li>1. Adjust the level of the original tray paper sensor (S1)/registration sensor (S3).</li> <li>2. Adjust the original width detecting volume (VR).</li> <li>3. Adjust the original stop position. (See A. "Mechanical.")</li> <li>4. Adjust the sheet-to-sheet distance in reduced page composition mode. (See A. "Mechanical.")</li> <li>5. Initial setting for paper setting</li> </ol>
Original tray power sensor (S1)	<ol style="list-style-type: none"> <li>1. Adjust the level of the original tray paper sensor (S1)/registration sensor (S3)</li> </ol>
Registration sensor (S3)	<ol style="list-style-type: none"> <li>1. Adjust the level of the original tray power sensor (S1)/registration sensor (S3).</li> </ol>
Original width detecting volume (VR)	<ol style="list-style-type: none"> <li>1. Adjusting the original width detecting volume (VR)</li> </ol>

Table 5-109

### 2. Adjusting the Level of the Original Tray Paper Sensor (S1)/ Registration Sensor (S3)

- 1) Remove the cover of the DADF, and shift bit 4 of the DIP switch DSW1 on the DADF controller PCB.

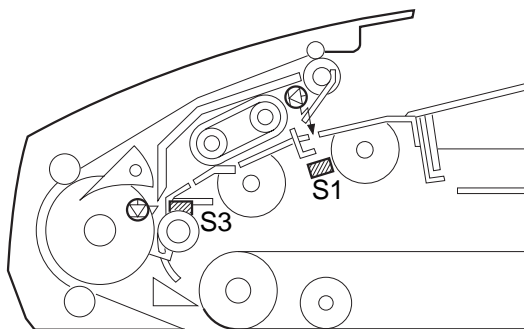

Figure 5-130

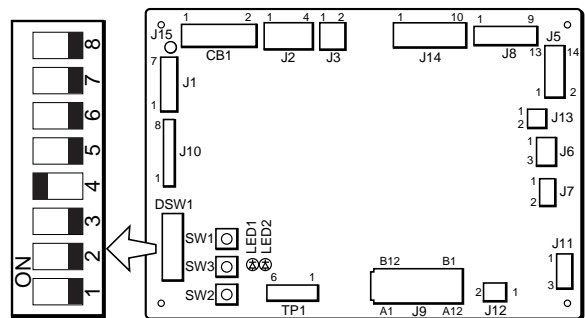

Figure 5-131

- 2) Push the push switch SW3 on the DADF controller PCB without placing any original on the original tray.
  - LED1/2 on the DADF controller PCB turns on.
  - If LED1 does not turn on in 30 sec or more, suspect the original tray paper sensor (S1); if LED2 does not turn on in 30 sec or more, suspect the registration sensor S3 or the DADF controller.

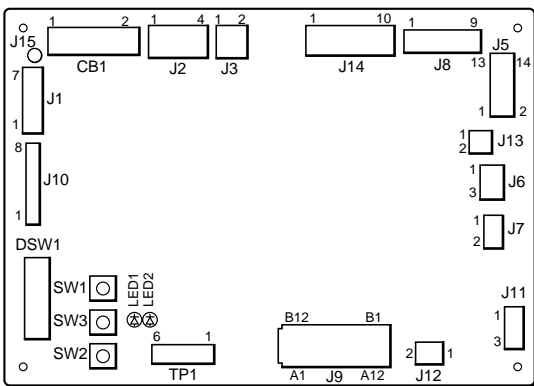
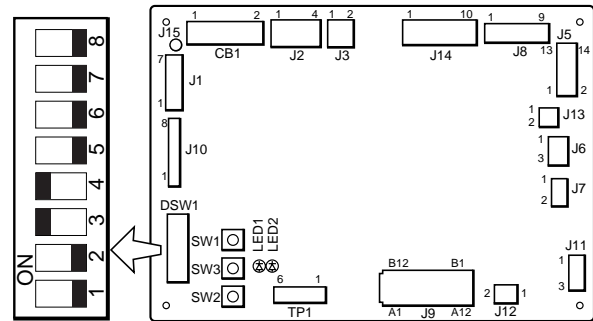

Figure 5-132

- 3) When LED1/2 has turned on, press the push switch SW3 on the DADF controller PCB once again.
  - The two LEDs will turn off, and the adjustment will end.
- 4) Shift the bit on the DIP switch DSW1 on the DADF controller PCB back to position.

### 3. Adjusting the Original Width Detecting Volume (VR1)

- 1) Obtain one sheet of A4 or LTR copy paper.
- 2) Remove the cover of the DADF, and set the bits of the DIP switch DSW1 on the DADF controller PCB as follows: (Keep in mind that settings differ according to the size of copy paper.)



A4

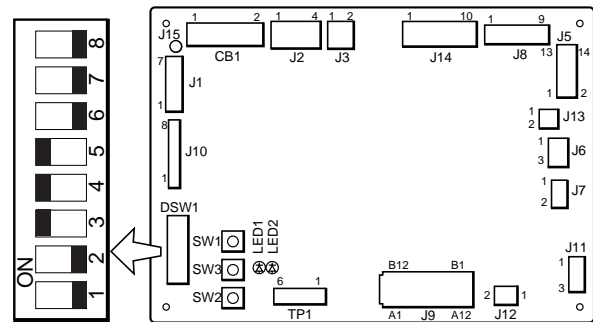

LTR

Figure 5-133



- 3) Place the copy paper in A4/LTR orientation, and adjust the side guides to the width of the copy paper.

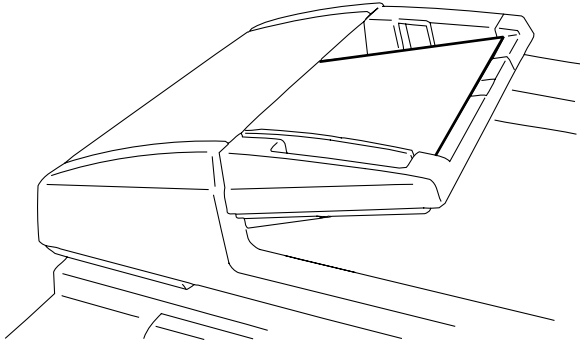

Figure 5-134

- 5) After LED2 has turned on, place the copy paper on the document tray in a different orientation (A4R/LTRR), and adjust the side guides to the width of the copy paper.

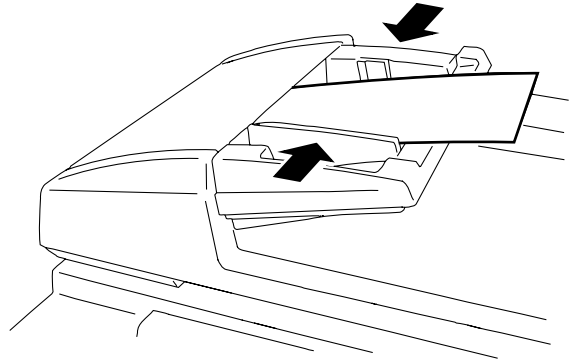

Figure 5-136

- 4) Press the push switch SW3 on the DADF controller PCB.
  - When the DADF controller reads data, LED1 will turn on and then turn off immediately; thereafter, LED2 will turn on.

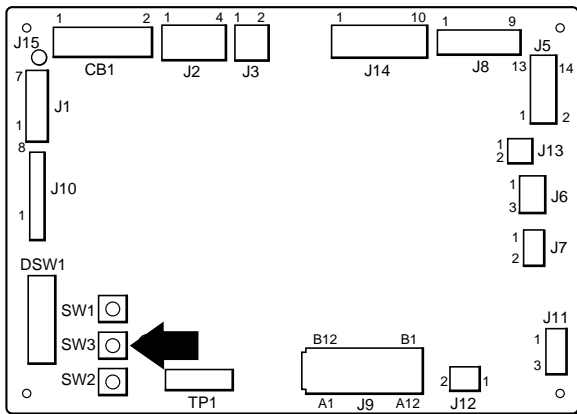

Figure 5-135

- 6) Press the push switch SW3 on the DADF controller PCB.
  - When adjustment ends successfully, LED1 and LED2 on the DADF controller PCB will turn on.
  - When adjustment ends in failure, LED1 and LED2 will flash.

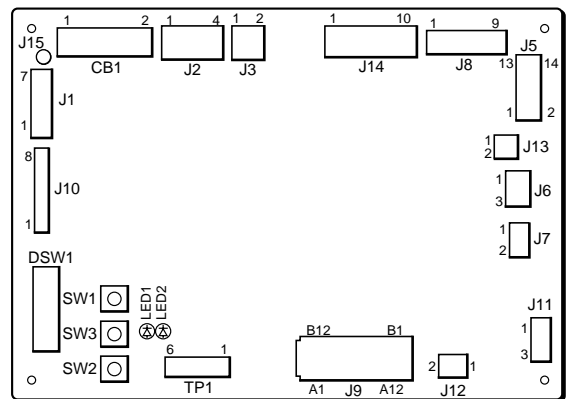
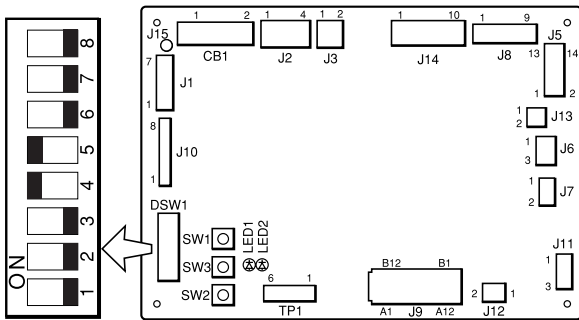

Figure 5-137

- 7) Shift the bits of the DIP switch DSW1 on the DADF controller PCB back to their initial position.

**4. Initial setting for paper pick up**

- 1) Remove the cover of the DADF, and set bit 4 and 5 of the DIP switch DSW1 on the DADF controller PCB to ON.



**Figure 5-138**

- 2) Press the push switch SW3 on the DADF controller PCB once.
- 3) Press the push switch SW2 on the DADF controller PCB 5 times after the pick up assembly will move.
- 4) Press the push switch SW3 on the DADF controller PCB once again.
- 5) Return the DIP switch DSW1 on the DADF controller PCB back to its original position.

## II. TROUBLESHOOTING

### A. Troubleshooting Malfunctions

#### 1. E401

Parts	Step	Checks	Yes/No	Action
Pick-up roller sensor (S5)	1	Set the meter range to 20 VDC, and connect the + probe to J5-1 and the - probe to J5-2 on the DADF controller PCB. Then, turn the flag (light-blocking plate) on the pick-up roller shaft by hand. Is the voltage about 5 V when the flag is at the sensor and about 0.15 V otherwise.	No	
Pick-up motor (M1)	2	Set the meter range to 200 VDC, and connect the + probe to J12-1 and the - probe to J12-2 on the controller PCB. Does the reading change to 22 V when the Copy Start key is pressed?	Yes	Check the wiring from the pick-up motor (M1) to the DADF controller PCB; if normal, replace the pick-up motor (M1).
			No	Replace the DADF controller PCB.

Table 5-201

#### 2. E402

Parts	Step	Checks	Yes/No	Action
Belt motor clock sensor (S10)	1	Set the meter range to 20 VDC, and connect the + probe to J9-B4 and the - probe to J-B3 on the DADF controller PCB. Does the reading repeat 5 and 0 V when the clock disk is turned slowly by hand?	No	Check the wiring from the belt motor clock sensor (S10) to the DADF controller PCB; if normal, replace the belt motor clock sensor (S10).
Belt motor (M3)	2	Set the meter range to 200 VDC, and connect the + probe to J7-1 and the - probe to J7-2 on the controller PCB. Does the reading change to 23 V when the Copy Start key is pressed?	Yes	Check the wiring from the belt motor (M3) to the DADF controller PCB; if normal, replace the belt motor (M3).
			No	Replace the DADF controller PCB.

Table 5-202

3. E403

Parts	Step	Checks	Yes/No	Action
Feeding motor clock sensor (S9)	1	Set the meter range to 20 VDC, and connect the + probe to J9-A11 and the - probe to J9-A10 on the DADF controller PCB. Does the reading repeat 5 and 0 V when the clock disk is turned slowly by hand?	No	Check the wiring from the feeding motor clock sensor (S9) to the DADF controller PCB; if normal, replace the feeding motor clock sensor (S9).
Feeding motor (M2)	2	Set the meter range to 200 VDC, and connect the + probe to J11-1 and the - probe to J11-2 on the DADF controller PCB. Does the reading of the meter change to 23 V when the Copy Start key is pressed?	Yes	Check the wiring from the feeding motor (M2) to the DADF controller PCB; if normal, replace the feeder motor (M2).
			No	Replace the DADF controller PCB.

Table 5-203

4. E404

Parts	Step	Checks	Yes/No	Action
Deliver motor clock sensor (S13)	1	Set the meter range to 20 VDC, and the - probe to J14-1 on the DADF controller PCB. Does the reading repeat 5 and 0 V when the clock disk is turned slowly by hand?	No	Check the wiring from the delivery motor clock sensor (S9) to the DADF controller PCB; if normal, replace the delivery motor clock sensor (S13).
Delivery motor (M5)	2	Set the meter range to 200 V DC, and connect the + probe to J14-8 and the - probe to J14-7 on the DADF controller PCB. Does the reading change to 23 V when the Copy Start key is pressed?	Yes	Check the wiring from the delivery motor (M5) to the DADF controller PCB; if normal, replace the delivery motor M5.
			No	Replace the DADF controller PCB.

Table 5-204

5. E411

Parts	Step	Checks	Yes/No	Action
Original tray paper sensor (S1) Registration sensor (S3)	1	Adjust the levels of the original tray paper sensor and the registration sensor. Is the problem corrected?	Yes	Adjust the levels of every sensors.
	2	Is the light-receiving section of each sensor soiled with paper lint?	Yes	Clean the light-receiving side of the sensor with a cotton wad.
Original tray paper sensor (S1) Registration sensor (light-receiving) (LED3)	3	Measure the voltage between the connectors J5-7 and J5-9 on the DADF controller PCB (original paper sensor) and between the connectors J9-B10 and J9-B9 (registration sensor light-receiving side). Is it about 0.6 to 1.1 V?	No	Check the wiring; if normal, replace the original tray paper sensor (S1) or the registration sensor light-receiving side (LED3)
Original tray paper sensor (S1)	4	Measure the voltage between the connectors J5-8 and J5-9 on the DADF controller PCB. Is it 1.5 V or less in the presence of paper and 4.0V or more in the absence of paper?	Yes	Replace the original tray paper sensor (S1).
			No	Replace the DADF controller PCB.
Registration sensor	5	Measure the voltage between the connectors J9-B12 and J9-B11 on the DADF controller PCB. Is it 4.5 V or more in the presence of paper and 1.3 V or less in the absence of paper?	Yes	Replace the registration sensor (S3).
			No	Replace the DAF controller PCB.

Table 5-205

6. E712

Parts	Step	Checks	Yes/No	Action									
	1	Turn off and then on the power switch. Is the problem corrected?	YES	End. (Check the wiring between the copier's DC controller PCB and the DADF controller PCB.)									
Wiring	2	Set the meter range to 200 VDC, and connect the meter probes as indicated. Is the voltage about 24 V?  <table border="1" style="margin-left: auto; margin-right: auto;"> <tr> <td></td> <td>+ probe</td> <td>- probe</td> </tr> <tr> <td>1</td> <td>J2-1</td> <td>J2-2</td> </tr> <tr> <td>2</td> <td>J1-6</td> <td></td> </tr> </table>		+ probe	- probe	1	J2-1	J2-2	2	J1-6		NO	Check the wiring for power from the copier.
	+ probe	- probe											
1	J2-1	J2-2											
2	J1-6												
DADF controller PCB	3	Replace the DADF controller PCB. Is the problem corrected?	YES	End.									
			NO	Replace the copier's DC controller PCB.									

Table 5-206

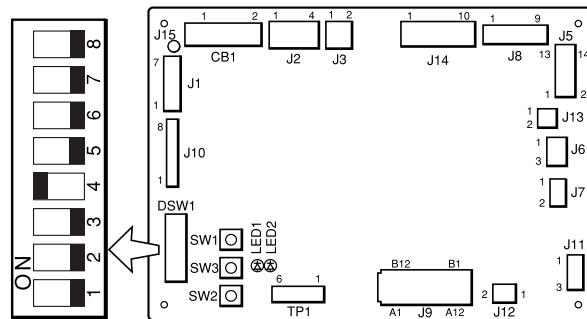

Figure 5-402

- 3) Turn on the copier's power switch.
- 4) With no original on the original tray, press the push switch SW3 on the DADF controller PCB once.
- 5) Check to make sure that LED1/LED2 on the DADF controller PCB turn on, and the voltage of TP2-1/TP2-2 is  $1.1 \pm 0.1$  V.



### III. ARRANGEMENT OF THE ELECTRICAL PARTS

#### A. Motors, Solenoids, and Sensors

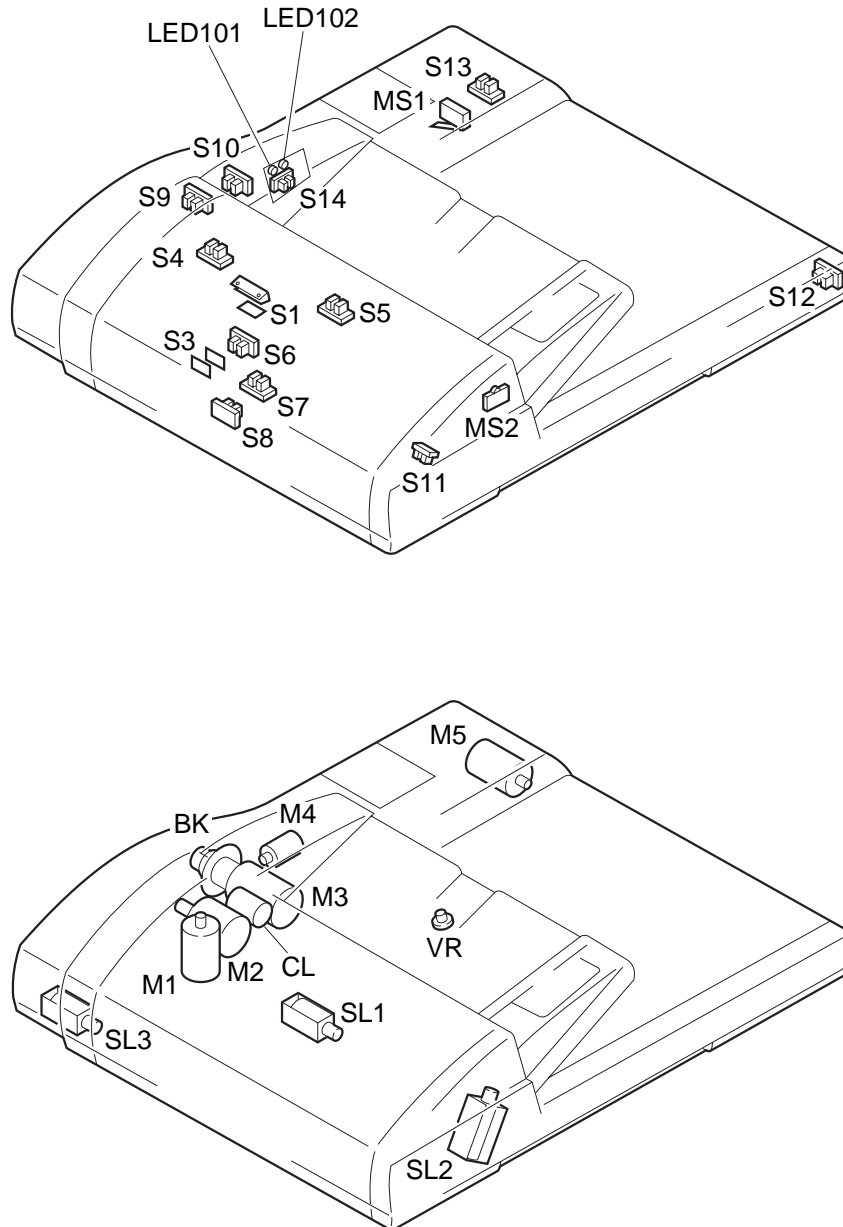

Figure 5-301





Symbol	Name	Notation	Description
	Motor	M1 M2 M3 M4 M5	Pick-up motor Feeder motor Belt motor Re-circulating motor Delivery motor
	Clutch	CL	Clutch
	Brake	BK	Belt motor brake
	Solenoid	SL1 SL2 SL3	Stopper plate solenoid Paper retaining plate solenoid Paper delivery plate solenoid
	Variable resistor	VR	Original width detecting volume
	Microswitch	MS1 MS2	DADF open/close switch Upper cover switch
	Phototransistor	S1 S3	Original tray paper sensor Registration sensor
	Photointerrupter	S4 S5 S6 S7 S8 S9 S10 S11 S12 S13 S14	Upper cover sensor Pick-up roller sensor Delivery sensor 1 Pick-up sensor Reversal sensor Feeding motor clock sensor Belt motor clock sensor Registration roller clock sensor Delivery sensor 2 Delivery motor clock sensor Re-circulation sensor
	LED	LED101 LED102	Original set indicator

Table 5-301

B. PCB

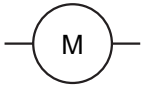
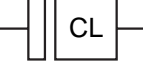
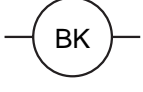
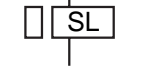
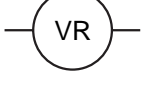
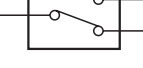
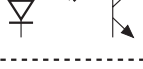
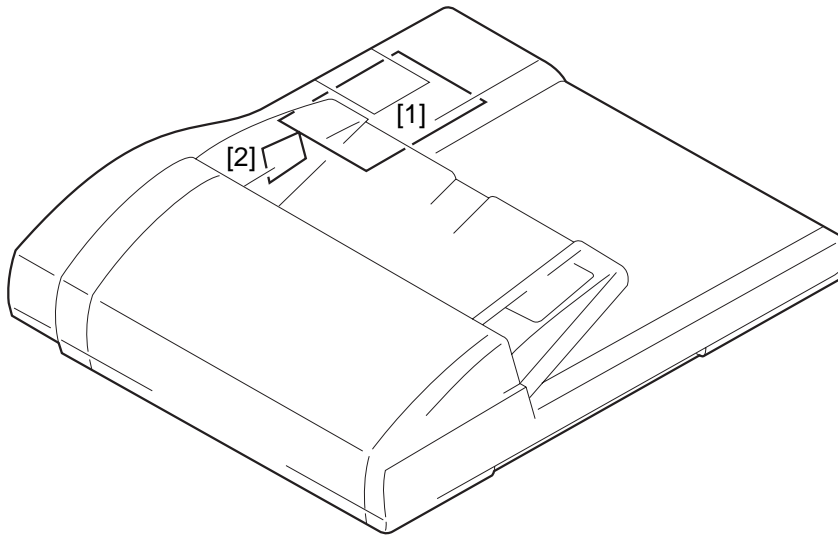

Table 5-302

Symbol	Name	Notation	Description
	DADF controller PCB	[1]	Controls the DADF.
	Indicator PCB	[2]	Indicates the presence of an original.

Table 5-302

## IV. VARIABLE RESISTORS, LIGHT-EMITTING DIODES, AND CHECK PINS BY PCB

Of all variable resistors (VR), light-emitting diodes, and check pins, those needed when servicing the machine in the field are discussed.

**Caution:**

Do not touch the variable resistors and check pins not discussed herein. They are for the factory, and require special tools and must be adjusted to high accuracy.

### A. DADF Controller PCB

**Caution:**

1. Some LEDs emit dim light even when off because of leakage current. This is a normal condition, and must be kept in mind:
2. VRs that may be used in the field  
VRs that must not be used in the field

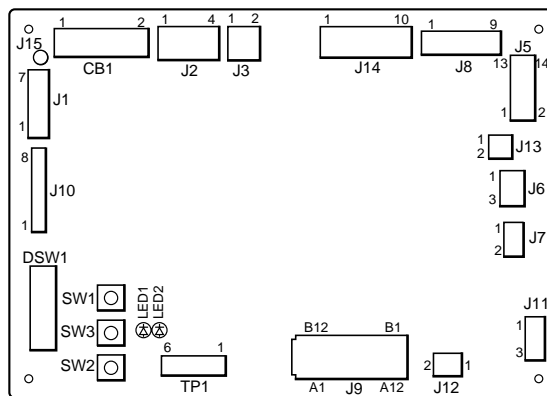

Figure 5-401

LED	Description
LED1	Use it when checking the output of the original tray paper sensor.
LED2	Use it when checking the output of the registration sensor.

Table 5-401  
LEDs on the DADF Controller PCB

Test pin No.	Checks
TP1-1	Output of the original tray paper sensor
-2	Output of the registration sensor
-3	For factory
-4	For factory
-5	+5V
-6	GND

**Table 5-402**  
**Test Pins on the DADF Controller PCB**

- Checking the Output of the Original Tray Paper Sensor/Registration Sensor  
If you have replaced the DADF controller PCB, original tray paper sensor, or registration sensor in the field, you must make sure that the output of each sensor is correct. (The light-emitting unit and the light-receiving unit of these sensors are not of a single entity.)

**Making Checks**

- 1) Turn off the copier's power switch.
- 2) Shift bit 4 of the DIP switch DSW on the DADF controller PCB to on.

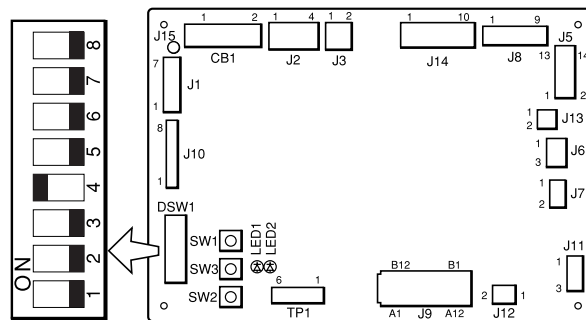

**Figure 5-402**

- 3) Turn on the copier's power switch.
- 4) With no original on the original tray, press the push switch SW3 on the DADF controller PCB once.
- 5) Check to make sure that LED1/LED2 on the DADF controller PCB turn on, and the voltage of TP1-1 is  $1.1 \pm 0.1$  V and the voltage of TP1-2 is  $4.1 \pm 0.2$  V.  
If the voltage of either TP1-1 or TP1-2 is not as indicated, suspect displacement of the light-emitting/-receiving unit of the sensor corresponding to the probe of the meter. Check the position of the sensor.

**B. Indicator PCB**

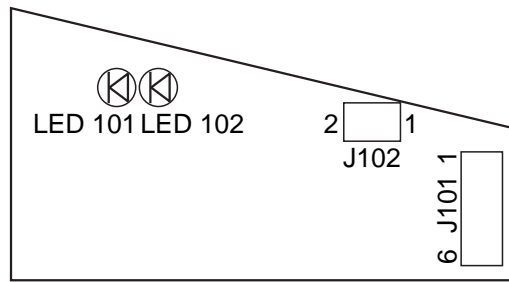

**Figure 5-403**

LED	Description
LED101	Indicates the presence of an original.
LED102	Indicates the presence of an original.

**Table 5-403**  
**LEDs on the Indicator PCB**

### C. DIP Switch Functions

The DIP switch DSW1 on the DADF controller PCB have the functions shown in Table 5-403.





Normal operation mode	DSW1 setting	Purpose
Normal operation		With all bits at OFF, the machine is in normal operation state.
Pick-up/delivery step operation		Each press on the push switch SW3 on the DADF controller PCB causes the machine to repeat pick-up/delivery operation.
Reduced page composition mode sheet-to-sheet distance adjustment	 (top pick-up)	A press on the push switch SW3 on the DADF controller PCB will cause the machine to pick-up two originals and stop them on the copyboard side by side. Thereafter, press the push switch SW1/SW2 as necessary to adjust the sheet-to-sheet distance. At the end, press the push switch SW3 to store the new setting.
Pick-up/reversal/delivery step operation		Each press on the push switch SW3 on the DADF controller PCB will cause the machine to repeat pick-up/reversal/delivery operation.
Original stop position	 (top pick-up)	A press on the push switch SW3 on the DADF controller PCB will cause the machine to pick-up an original and stop it on the copyboard glass. Thereafter, press the push switch SW1/SW2 to adjust the original stop position. At the end, press the push switch SW3 to store the new setting.
Continuous pick-up/delivery operation		Place three or more sheets of copy paper on the original tray, and press the push switch SW3 on the DADF controller so that the machine will repeat pick-up/delivery operation continuously.
Sensor level check		Each press on the push switch SW3 on the DADF controller PCB will put the original tray paper sensor/registration sensor in level check mode.

Table 5-403a

Normal operation mode	DSW1 setting	Purpose						
Non-default size original		<p>Shift bit 7 to on if any of the following sizes is used:</p> <table border="1" data-bbox="826 353 1428 517"> <thead> <tr> <th data-bbox="826 353 1083 409">DADF model</th> <th data-bbox="1083 353 1428 409">Length in feeding direction (mm)</th> </tr> </thead> <tbody> <tr> <td data-bbox="826 409 1083 465">A/B-configuration</td> <td data-bbox="1083 409 1428 465">220 to 250</td> </tr> <tr> <td data-bbox="826 465 1083 517">Inch-configuration</td> <td data-bbox="1083 465 1428 517">220 to 260</td> </tr> </tbody> </table>	DADF model	Length in feeding direction (mm)	A/B-configuration	220 to 250	Inch-configuration	220 to 260
DADF model	Length in feeding direction (mm)							
A/B-configuration	220 to 250							
Inch-configuration	220 to 260							
Separation belt/feeding roller cleaning	 <p>(top pick-up mode)</p>	<p>A press on the push switch SW3 on the DADF controller PCB will cause the pick-up motor to rotate to clean the separation belt and the feeding roller. To stop, press the push switch SW3 once again.</p>						
Original size horizontal direction detection	 <p>(A4 size)</p>  <p>(LTR size)</p>	<p>Use it to store the position of the side guides of the original tray for A4 or LTR size originals.</p>						

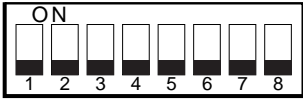
Table 5-403b

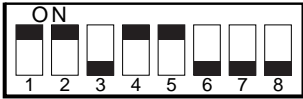
## V. SELF DIAGNOSIS

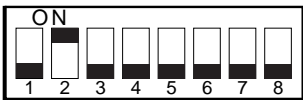
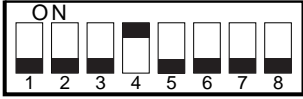
### A. DADF Self Diagnosis

The microprocessor on the machine's DADF controller PCB is provided with a function which checks the state of the machine and, upon detection of an error, will indicate an error code on the copier's control panel.

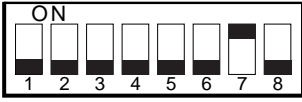
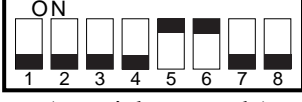
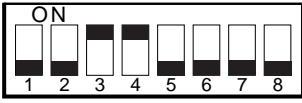
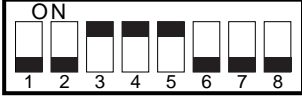
Code	Cause	Description
E401	<ul style="list-style-type: none"> <li>The pick-up motor (M1) does not rotate.</li> <li>The pick-up roller sensor (S5) is faulty.</li> </ul>	<ul style="list-style-type: none"> <li>A flag is mounted on the spindle of the pick-up motor (M1), and the rotation of the pick-up motor is mounted in reference to the flag blocking the pick-up roller sensor (S5). This error is identified when the sensor does not turn on and off twice or more within 1 sec</li> </ul>
E402	<ul style="list-style-type: none"> <li>The belt motor (M3) does not rotate.</li> <li>The belt motor sensor (S10) is faulty.</li> </ul>	<ul style="list-style-type: none"> <li>The number of belt motor clock pulses within 200 msec is lower than specific value.</li> </ul>
E403	<ul style="list-style-type: none"> <li>The feeder motor (M2) does not rotate.</li> <li>The feeder motor clock sensor (S9) is faulty.</li> </ul>	<ul style="list-style-type: none"> <li>The number of feeder motor clock pulses within 200 msec is lower than a specific value.</li> </ul>
E404	<ul style="list-style-type: none"> <li>The delivery motor (M5) does not rotate.</li> <li>The delivery motor clock sensor (S13) is faulty.</li> </ul>	<ul style="list-style-type: none"> <li>The number of feeder motor clock pulses within 200 msec is lower than a specific value.</li> </ul>
E411	<ul style="list-style-type: none"> <li>The original tray paper sensor (S1) is faulty.</li> <li>The registration sensor (S3) is faulty.</li> </ul>	<ul style="list-style-type: none"> <li>The output of the sensor is 2.3 V or higher in the absence of paper.</li> </ul>
E712	<ul style="list-style-type: none"> <li>The communications IC on the feeder side is faulty.</li> </ul>	<ul style="list-style-type: none"> <li>The communications with the copier is disrupted for 5 sec or more.</li> </ul>

Table 5-501

**Caution:**

- When the self diagnostic mechanism has turned on, the copier may be reset by turning it off and then on.
- When the DADF is out of order, copies may still be made by placing originals on the copyboard glass.



---

---

# APPENDIX

---

A. GENERAL TIMING CHART .....	A-1	D. DADF CONTROLLER CIRCUIT	
B. NAMES AND ABBREVIATIONS OF		DIAGRAM .....	A-4
SIGNALS.....	A-2	E. DISPLAY BOARD.....	A-11
C. DADF-C1 GENERAL CIRCUIT		F. SPECIAL TOOLS .....	A-12
DIAGRAM .....	A-3	G. SOLVENTS AND OILS .....	A-13



# A. GENERAL TIMING CHART

1. top pick-up mode, A4, 2 originals (single-sided original to single copy)

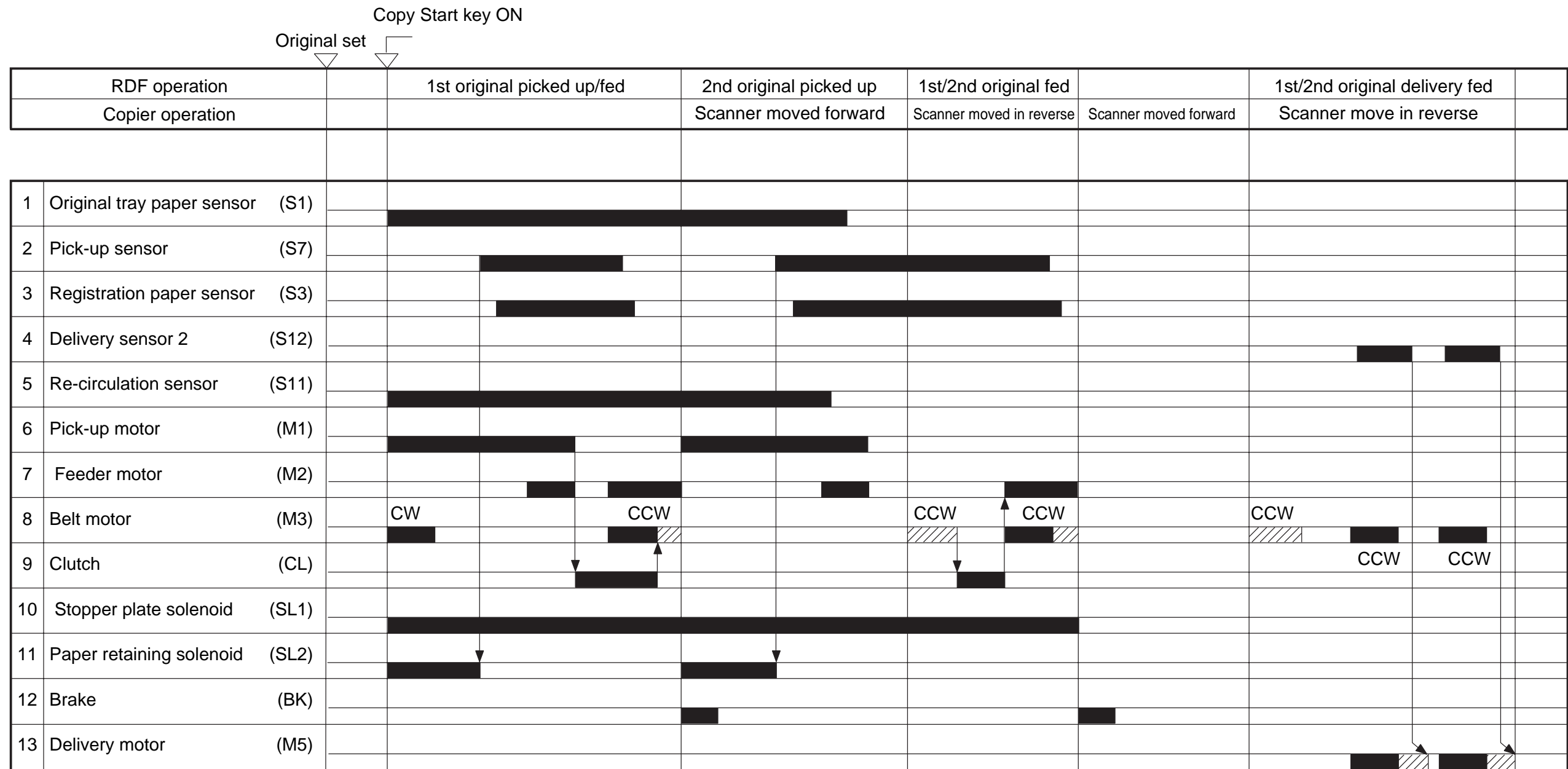

: Motor low-speed rotation.

CW : (copier mode delivery direction) rotation.

CCW : rotation(pick-up direction) rotation.

## B. NAMES AND ABBREVIATIONS OF SIGNALS

The following are the signal names and abbreviations used in this manual and circuit diagrams.

**Note:**

The abbreviations in parentheses are analog signals, which cannot be expressed in terms of '1' and '0'. Others are digital signals, which may be expressed in terms of '1' and '0'.

BDIR	BELT MOTOR ROTATION Command
BK	BRAKE DRIVE Command
BMCLK	BELT MOTOR CLOCK PULSE Signal
BMON	BELT MOTOR DRIVE Command
BMPWM	BELT MOTOR SPEED CONTROL Command
CL	CLUTCH DRIVE Command
CNCT	CONNECT Signal
EPMS	DOCUMENT ENPUTY1 Signal
FLPSL1	DEFLECTOR SOLENOID DRIVE Command
WIDTH	DOCUMENT SIZE DETECTION Signal
ORGLED	DOCUMENT SENC DRIVE Command
FMCLK	FEED MOTOR CLOCK PULSE Signal
FMPWM	FEED MOTOR DRIVE Command
RSS	LAST DOCUMENT DETECTION Signal
SPRS	PAPER DETECTION Signal 1
EJTS1	PAPER DETECTION Signal 2
ENTS	PAPER DETECTION Signal 3
EJTS2	PAPER DETECTION Signal 4
TURNS	PAPER DETECTION Signal 5
DCTS	PICK-UP ROLER START POSITION Signal
RFC	DADF CLOSED Signal
RSDRV	RECYCLE MOTOR DRIVE Command
RSIN	DADF SERIAL INPUT Signal
RSOUT	DADF SERIAL OUTPUT Signal
SDIR	PICK-UP MOTOR ROTATION Command
SMON	PICK-UP MOTOR DRIVE Command
SMPWM	PICK-UP MOTOR SPEED CONTROL Command
STPSLD	STOPPER SOLENOID DRIVE Command
UPCC	UPPER COVER CLOSED Signal 1
CVRSW	UPPER COVER CLOSED Signal 2
WGTSL	WEIGHT SOLENOID DRIVE Command

# C. DADF-C1 GENERAL CIRCUIT DIAGRAM

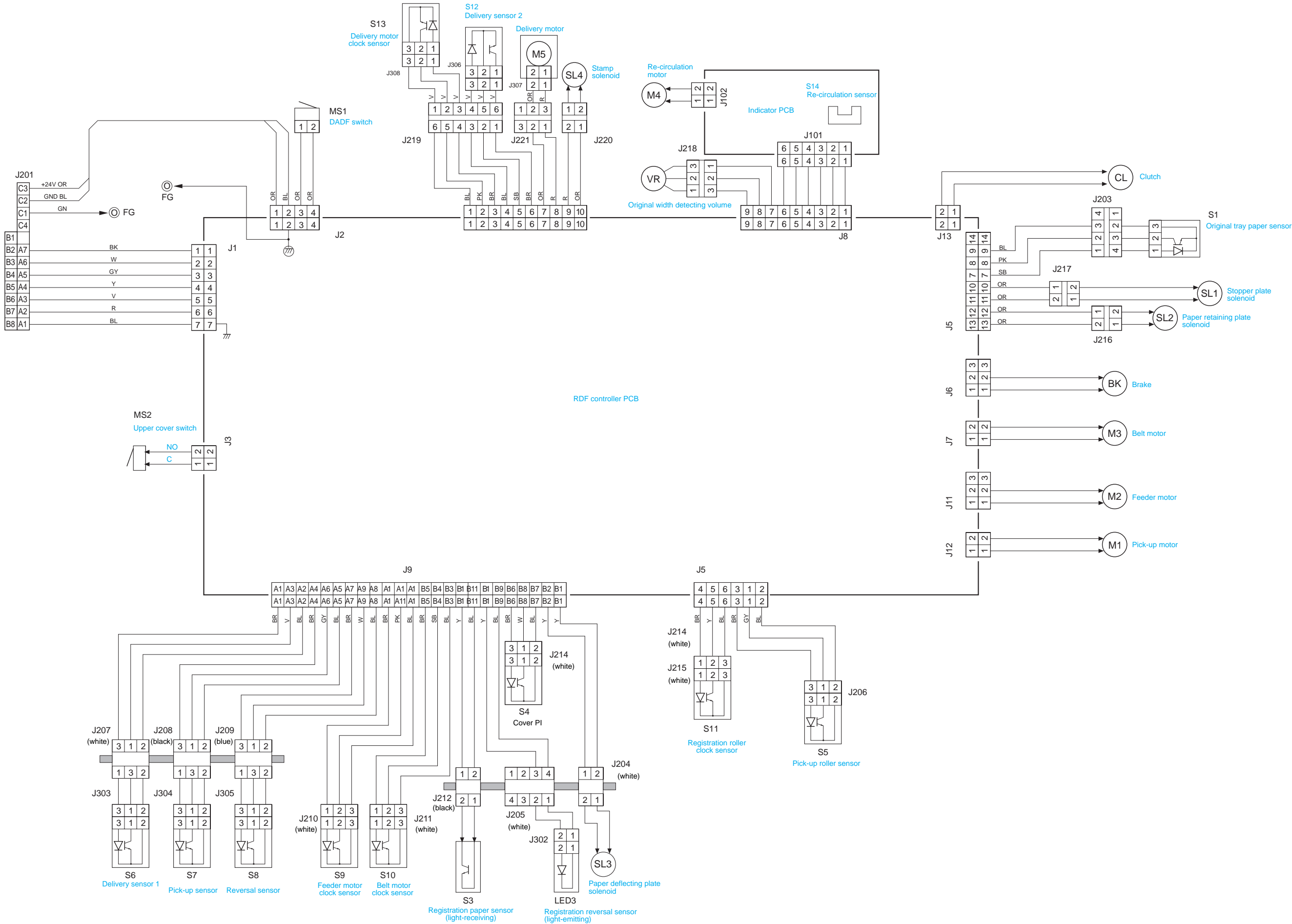

# D. DADF CONTROLLER CIRCUIT DIAGRAM (1/6)

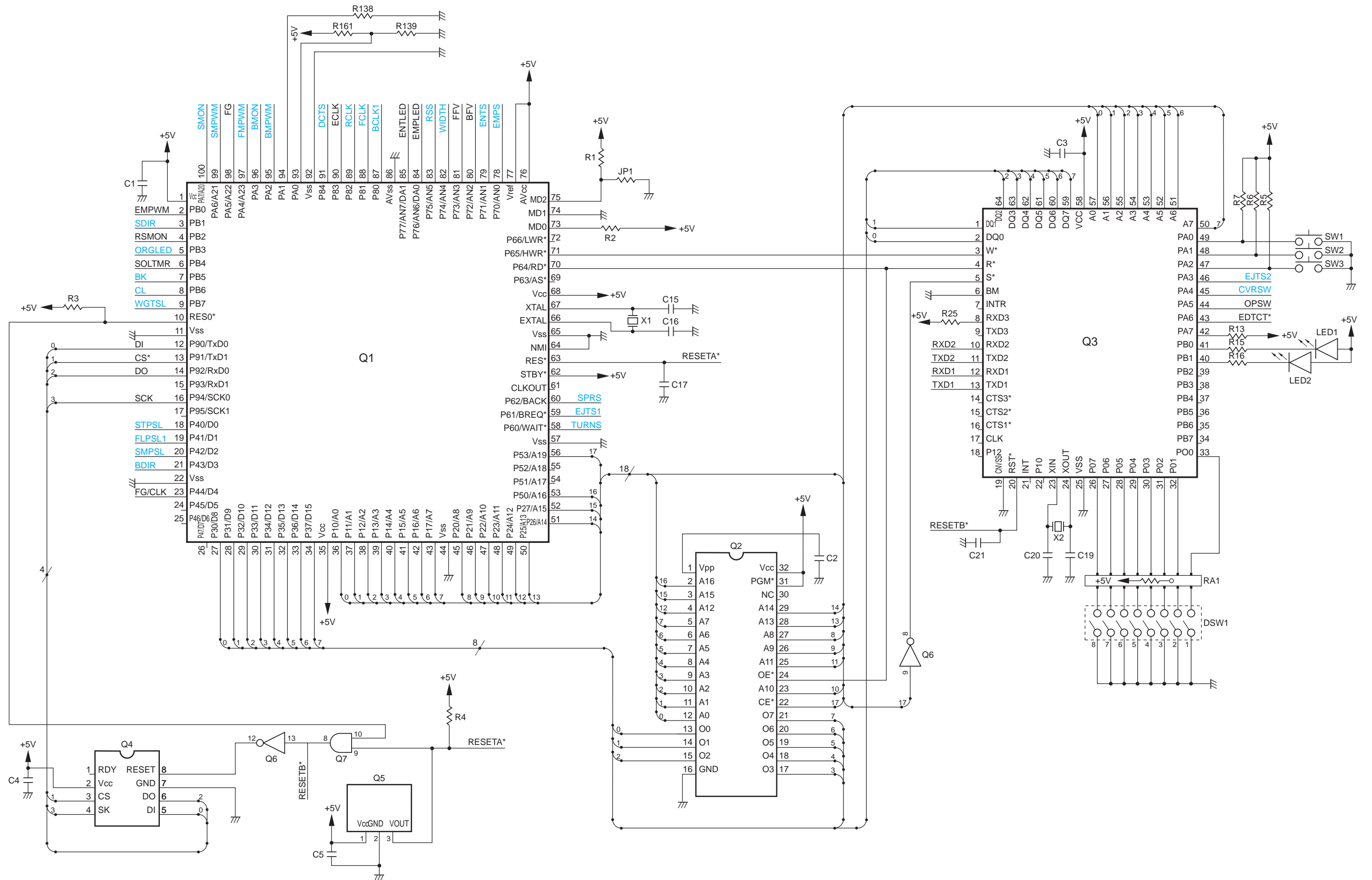

# D. DADF CONTROLLER CIRCUIT DIAGRAM (2/6)

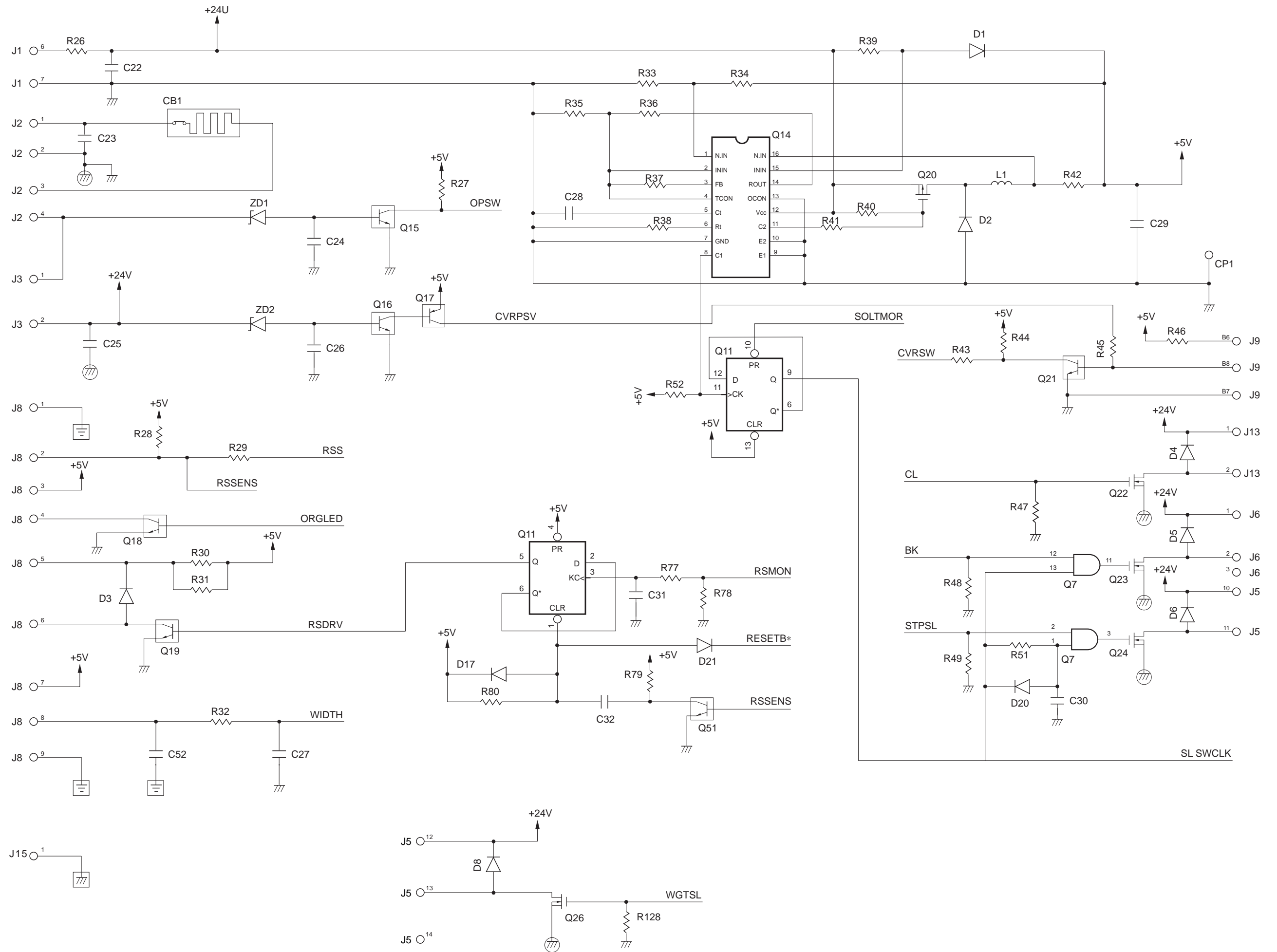

# D. DADF CONTROLLER CIRCUIT DIAGRAM (3/6)

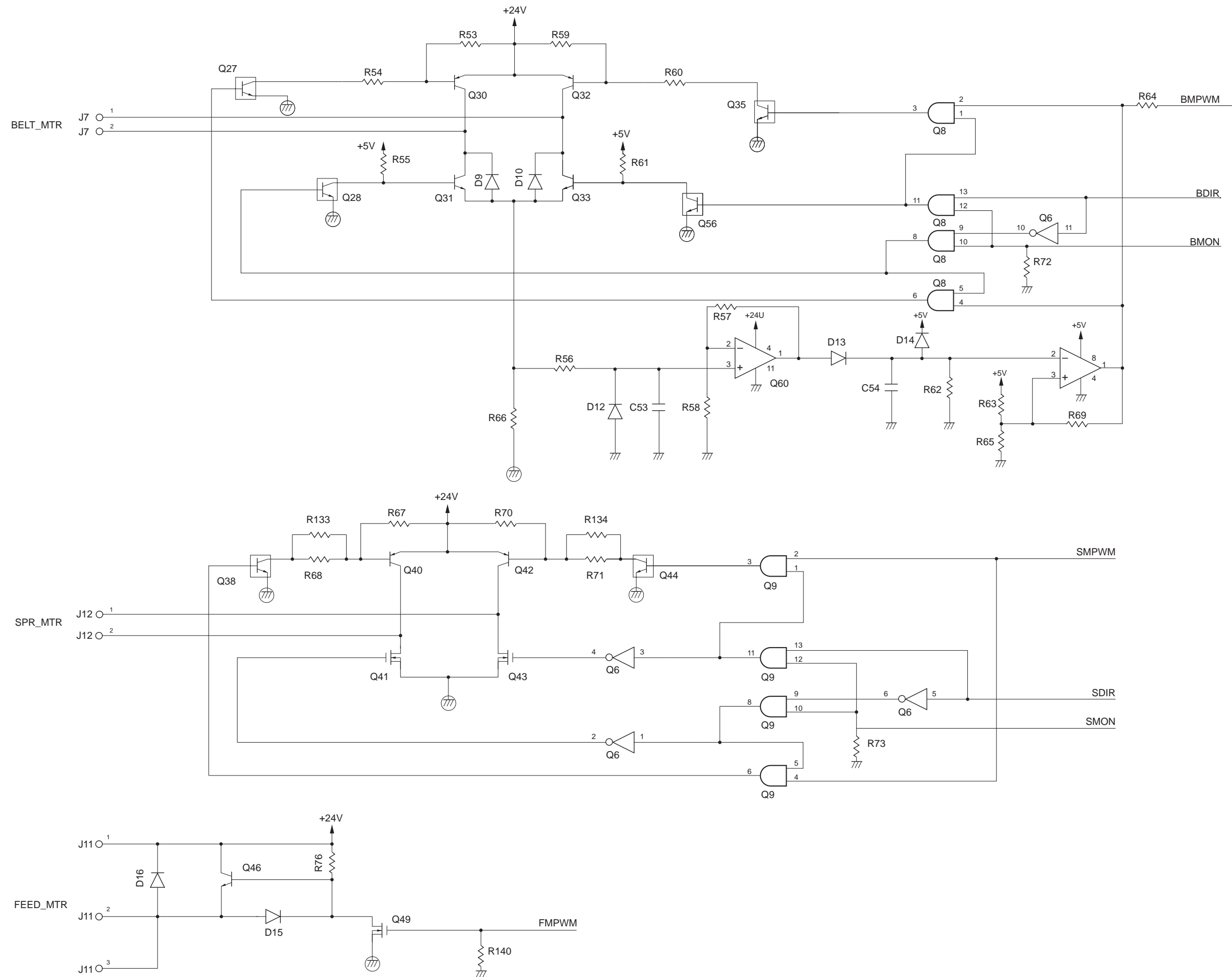



## D. DADF CONTROLLER CIRCUIT DIAGRAM (4/6)

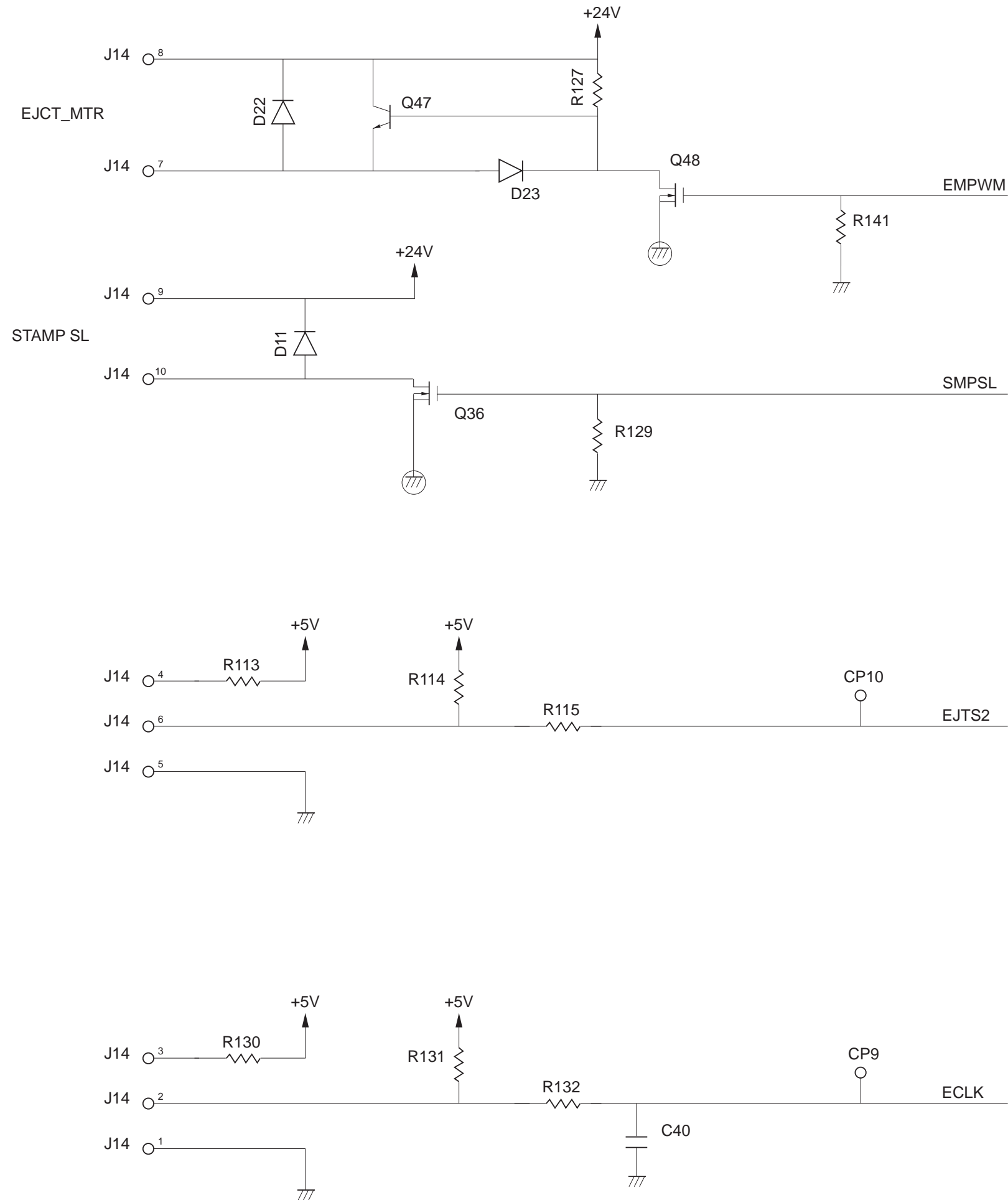

# D. DADF CONTROLLER CIRCUIT DIAGRAM (5/6)

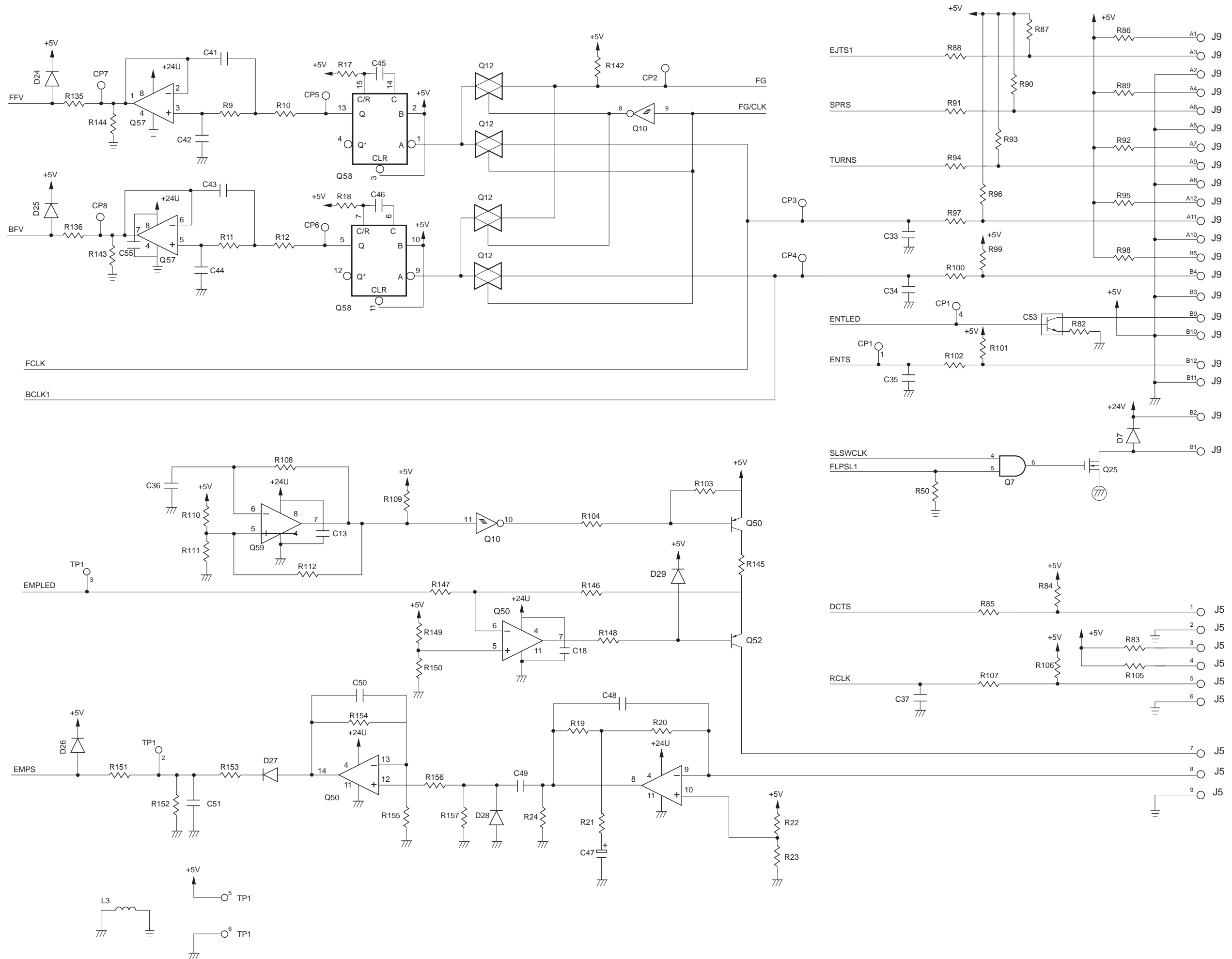

# D. DADF CONTROLLER CIRCUIT DIAGRAM (6/6)

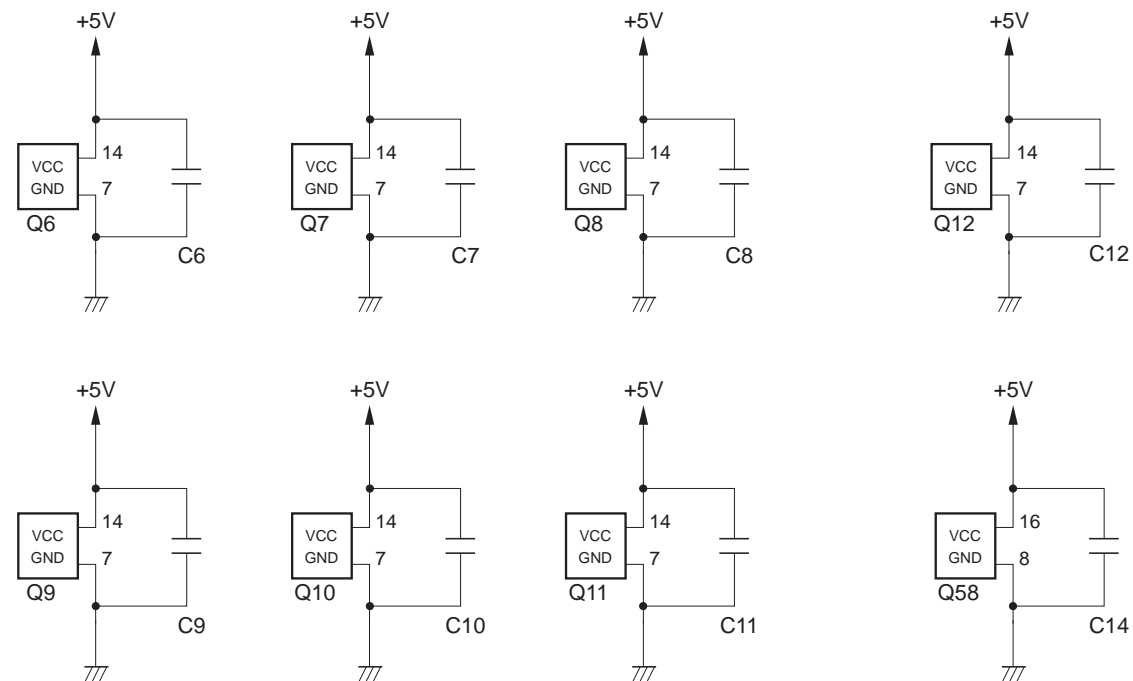
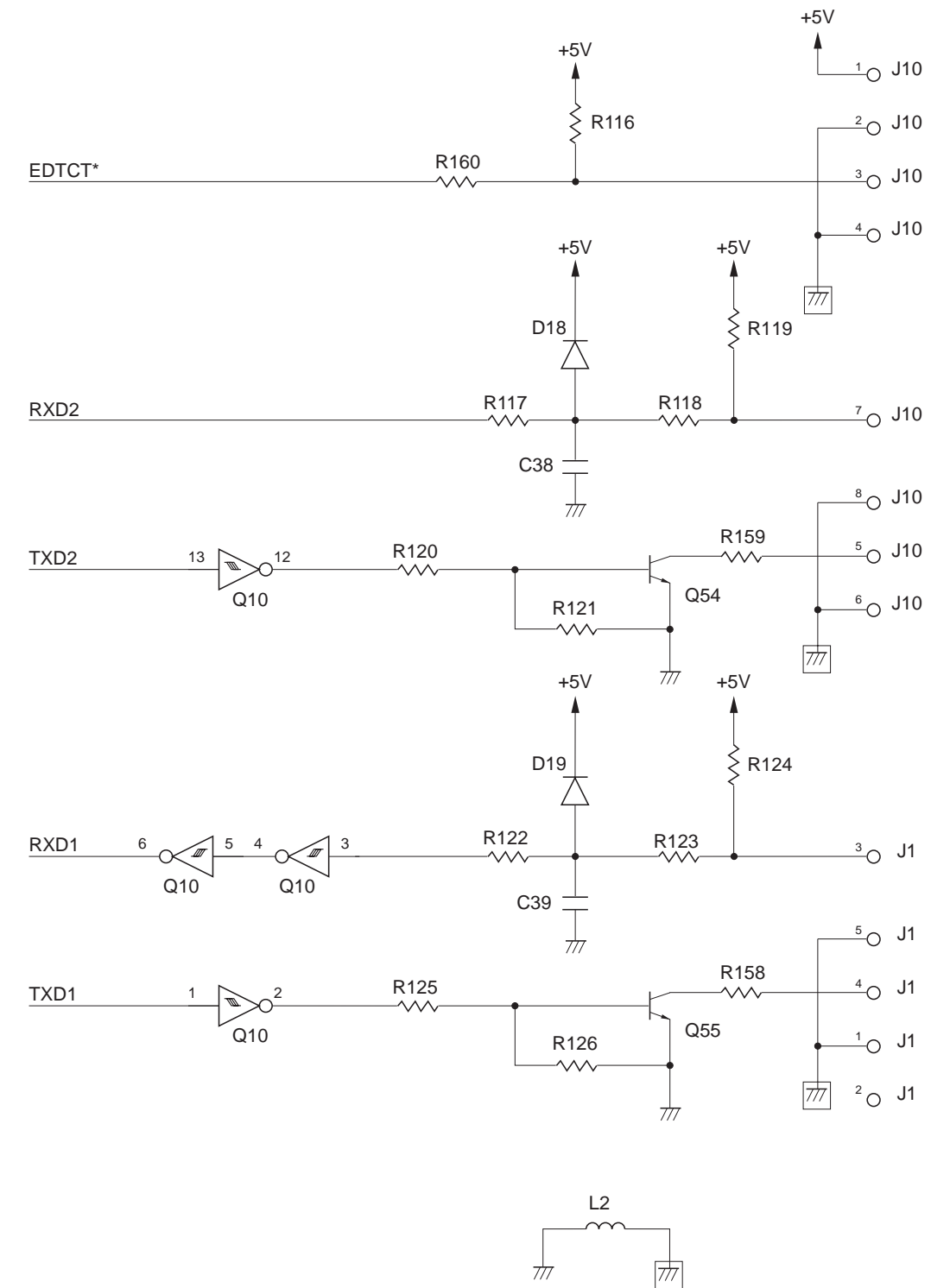

# E. DISPLAY BOARD

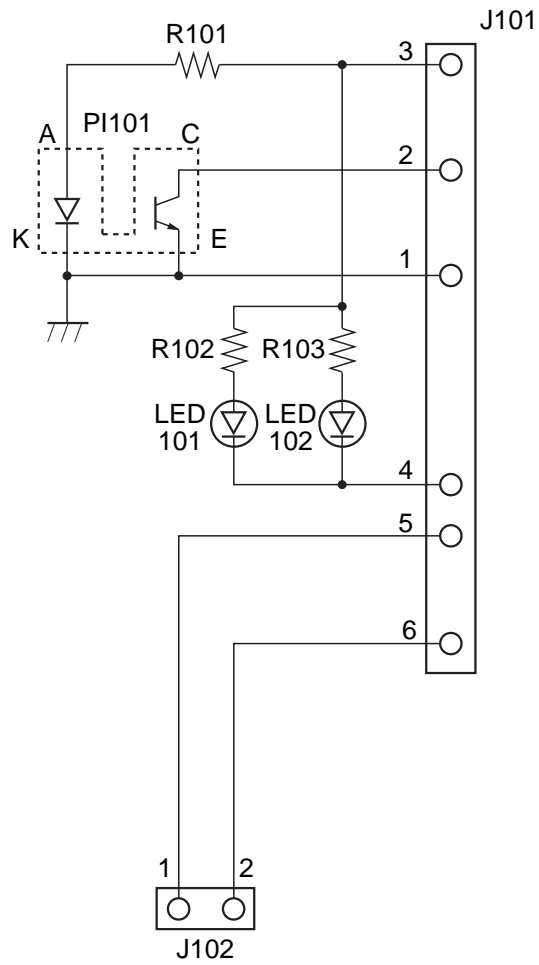

## F. SPECIAL TOOLS

You will need the following special tools in addition to the standard tools set:

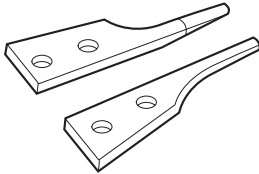
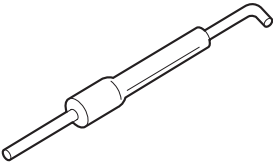
No.	Tool name	Tool No.	Shape	Rank	Uses
1	Stop ring •Pliers edge replacement	CK-0246		B	For removing clip rings (4 to 9 mm).
2	Tension gauge	CK-0058		B	For adjusting the tension on the timing belt, separation belt (0 to 600 g).

**The following applies:**

- A: Each service person is expected to carry one.
- B: Each group of five service persons is expected to carry one.
- C: Each workshop is expected to keep one.

## G. SOLVENTS AND OILS

No	Name	Uses	Composition	Remarks
1	Alcohol	Cleaning; e.g., glass, plastic, rubber (external covers).	Fluoride-family carbon hydrogen, alcohol, surface activating agent, water	<ul style="list-style-type: none"> <li>•Do not bring near fire.</li> <li>•Procure locally.</li> </ul>
2	Lubricant	Lubricating	Silicone oil	Tool No.: CK-0551 (20 g)
3	Cleaning tissue	Cleaning; e.g., feeding belt, copyboard cover, copyboard glass		Tool No.: TKN-0454



Prepared by  
Office Imaging Products Technical Support Dept.1  
Office Imaging Products Technical Support Div.  
Office Imaging Products Quality Assurance Center.  
CANON INC.  
Printed in Japan

REVISION 0 (JAN. 1999) (33130)

5-7, Hakusan, 7-chome, Toride-City, Ibaraki-Pref., 302-8501, Japan



# Canon



This publication is printed on  
70% reprocessed paper.